

ARIA-7R7

Professional Quality Studio Monitors for Mixing, Mastering, and Critical Listening

Designed by: Spencer Beasley

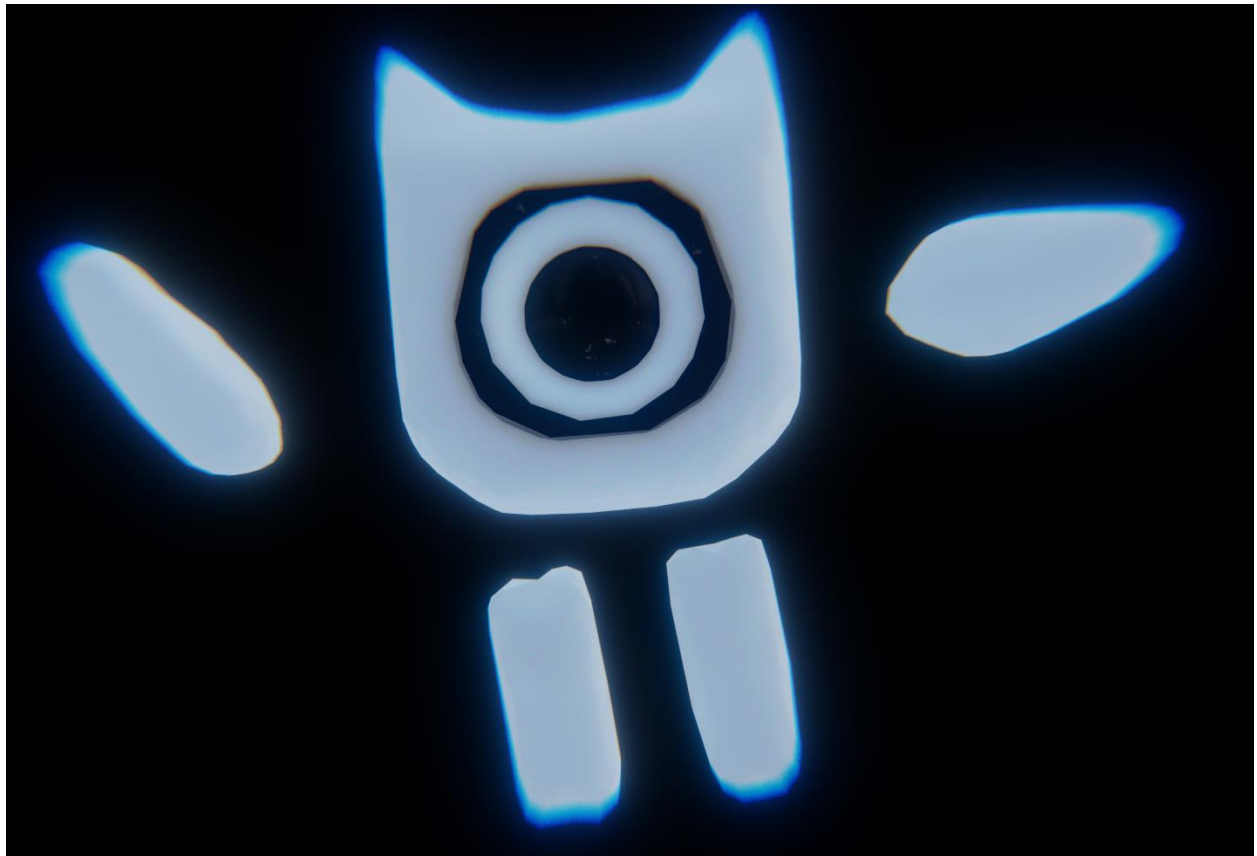

Table of Contents

1.0 Functional Description	3
2.0 Reference Systems	4
2.1 Overview	4
2.2 Specific Loudspeakers	4
Adam Audio S5H	4
Barefoot MicroMain26.....	5
ATC SCM45A Pro	6
3.0 Technical Specifications.....	6
3.1 Cabinet Design	6
3.2 SPL.....	6
3.3 Frequency Response	8
4.0 Tweeter Comparison	8
Tweeter Selection.....	12
5.0 Woofer Comparison	13
Box Simulation	17
Woofer Selection.....	22
Amplifier Selection.....	22
6.0 Box Design.....	22
7.0 Construction.....	29
8.0 Testing	34
9.0 Tuning.....	43
Final Listening.....	45
10.0 What I Leaned	47
11.0 Final Cost.....	48
Bibliography	49

1.0 Functional Description

This speaker will be a full-range near/mid-field monitor for use by a single to multiple listeners at or near the mixing position. It will be employed in home studio environments where the setup will be built around sound quality first, allowing for greater flexibility in dimensions and volume. The speaker will not be desk mounted, rather placed on an isolation stand behind the listener's desk. The listening environment will be moderately treated, operating with the assumption of excluded vertically mounted treatment and the use of a desk in front of the listener. Thus, a Woofer-Tweeter-Woofer (WTW/MTM) driver layout will be used to minimize vertical reflections from the desk and ceiling. The speaker is intended only to be used in the vertical position as main monitors.

As a full-range monitor, this speaker must represent the full range of human hearing and thus should span 20Hz-20kHz. The ability to extend to 20Hz requires the use of subwoofer drivers, which will be fulfilled by my JBL LSR 310S subwoofer. This affords more flexibility of placement in smaller rooms and decreases the overall footprint of the main system. One enclosure can function as a subwoofer for both mains.

The system should reach a maximum of SPL of around 100dB. The SPL of the monitor system should be able to provide the same level of energy as a live recording session¹.

Sound quality is the defining principle in this system. It should produce an exceptionally flat response from 20Hz-20kHz with an exceedingly low amount of distortion. Every frequency should be represented equally with no coloration or tonal variance. Low Frequency Extension (LFE) and bass detail is of particular importance as this system will be used for mixing bass heavy genres. However, it should still sound accurate and detailed. The system is intended for listening back², to pick out mixing or recording errors; it should have blatant and unapologetically true sound.

Weight and portability of are minimal concern as these will be semi-permanent (relocated when moving), but they should be able to be adjusted and moved by an average individual.

From John L. Murphey's three-point design tradeoffs³, this system will prioritize low-frequency extension first, SPL output second, and finally Size.

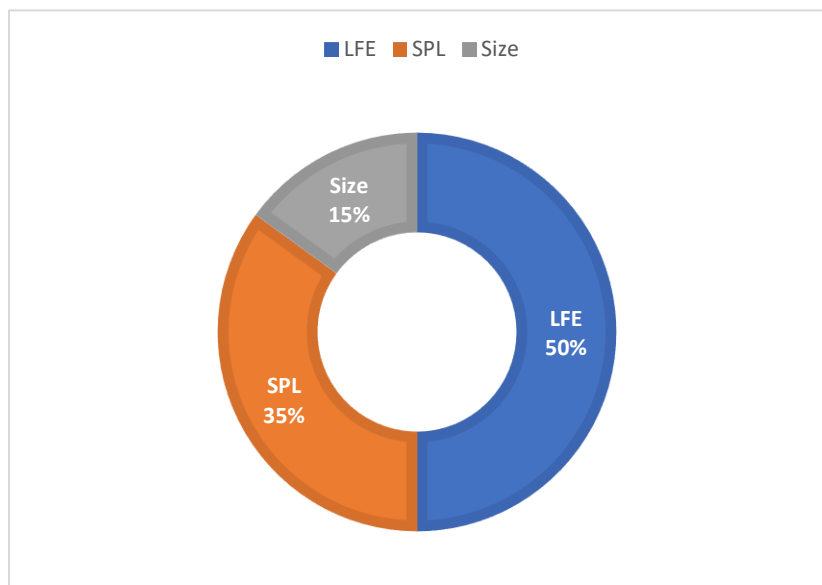

¹ Newell.

² Moulton, David.

³ John Murphy, *end.* p.55.

2.0 Reference Systems

2.1 Overview

This is a collection of high-performance studio monitors with varying woofer sizes and driver layouts. These were chosen for their linear response and/or WTW design and are referenced for frequency range and linearity relative to driver size, cost, and layout. Note that these measurements do not include the addition of a subwoofer, which will be a part of the MM12 system.

Model	Frequency Response	Max SPL	Woofer size (in)	Crossover (split)	Price (per)	Port
Adam Audio S5H	22Hz-50kHz	131 dB	10"	3-way	\$10K	Front
Neuman KH 310	34Hz-21kHz	110.3 dB	8.25"	3-way	\$2,495	N/A
Barefoot MicroMain26	30Hz-45kHz	---	10"	4-way	\$6,497	N/A
Genelec 8361A SAM	30Hz-43kHz	118 dB	10 3/8"	3-way	\$4,995	Back
Focal Twin 6 Be	40Hz-40kHz	115 dB	6.5"	2-way	\$2,200	Front
ATC SCM45A Pro	42Hz-25kHz	112 dB	6.5"	3-way	\$6,495	Front

Looking at these references we can see that low frequency response extends from around 40Hz down to 22Hz relative to their woofer size. This is already a great representation of human perception before the integration of a subwoofer. All SPL are reported above 110dB, with the exception of the Barefoot MicroMain26, which is more than enough to alter emotional response¹. Cost here is also an important factor as full range performance at high SPL is not cheap. We can look at these references and find where manufacturers saw opportunities to improve.

2.2 Specific Loudspeakers

Adam Audio S5H⁴



You could call this the heavy hitter of the bunch. One of Adam Audio's top of the line S model monitors, this produces an impressive frequency response of 22-50kHz with exceptional linearity across the board. This speaker features the legendary Adam Audio folded ribbon tweeter for extremely detailed and transparent high frequencies and a dome/cone hybrid MF driver. They both sit in a waveguide milled out of solid aluminum for great off-axis response. For low frequencies there are two 10" woofers with extended linear excursion. This speaker can also reach 131dB at one meter. However, it's clear you pay for that performance at a price of \$10,000 per box. Unfortunately, there is no frequency response graph for this speaker. Also, dispersion graphs would have been useful to compare against its vertical arrangement. It should be noted that to house two 10" drivers the enclosure must be quite large. The Adam Audio S series has been very popular with top engineers specifically for their transparency and imaging.

⁴ <https://www.adam-audio.com/en/s-series/s5h/>

Barefoot MicroMain26⁵



The Barefoot MicroMain26 is a very interesting entry in this reference list. At first we can see that the speaker employs a 3 way design, but there are actually two hidden 10" woofers in the sides which are mechanically locked together. This allows the MM26 to deliver a much deeper response with a much smaller footprint. Also unique is the ring radiator tweeter which uses an inverted horn design for optimal wide imaging. There are no available SPL

measurements, but it can be inferred that the maximum SPL will be limited due to the lack of a port. However, this lends itself to a more linear response. Looking at the graph we can see that the response is extremely linear on axis, varying by less than +/- 1dB! Even the off axis response fits within +/- 3dB up to 5kHz. With good reason, many professionals have come to rely on Barefoot for critical playback and listening.

13.0 MicroMain26 Frequency Response (Horizontal plane)

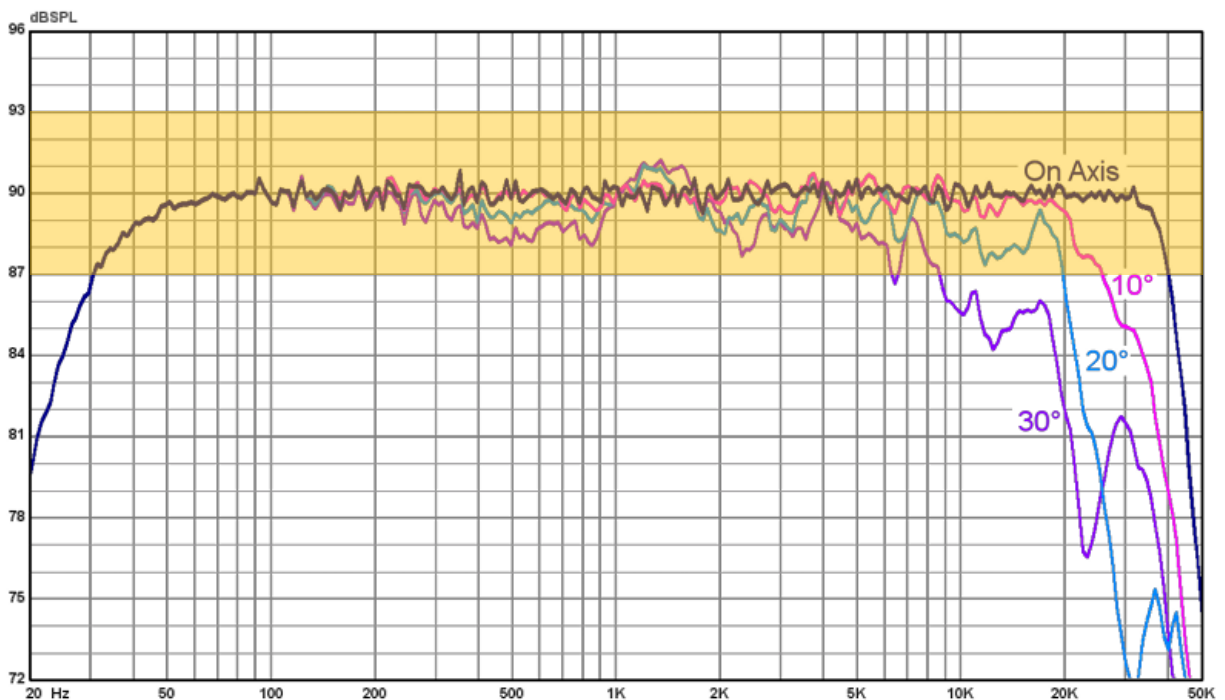

⁵ <https://barefootsound.com/micromain26/>

ATC SCM45A Pro⁶



This monitor comes from king of studio monitors ATC. It's another three-way design with really no gimmicks, just the highest quality drivers imaginable. All ATC drivers are designed and manufactured in house, like the hand made 6.5" woofers in this model. They reach a max SPL of 112dB which is perfectly suitable for studio use. Unfortunately, again there are no frequency response graphs, but ATC lists +/- 2dB from 70Hz-17kHz with a low cutoff of 42Hz. On paper these may not warrant the cost of \$13k a pair,

but they produce a sound that is incomparable and treasured by many. It's the engineering of the drivers and their interaction with box that make this speaker great. It also features a class A/B tri-amp pack which amplifies at very low distortion. Due to the lack of graphical documentation the off-axis performance is a bit of a mystery.

3.0 Technical Specifications

3.1 Cabinet Design

The first limitation of the speaker design to consider is overall footprint. For my situation, the listening setup will be dictated primarily by the speakers, then by the size of the room (i.e., where they are positioned). This gives me a great deal of flexibility in terms of size. However, with the implementation of a subwoofer, the size will be small enough to fit on standard monitor stands; they will be stand mounted, behind a large desk. These will not be floor standing towers, but a larger box will not be an issue as weight is of little consequence; these will not be moved around much. However, due to the implementation of a vertical MTM layout, a constraint must be placed on the vertical dimension. They must be tall enough to fully accommodate two 7" woofers and a 1" tweeter side by side, but not too tall as to have the upper woofer too far beyond the listening axis or be impractically large as to not fit on monitor stands. This is about 2ft top to bottom maximum. Horizontally, these speakers can be as wide as they need, but should be a maximum of 1.25ft representing Thiele's golden rule with Height:Width:Depth ratios (2.6:1.6:1)⁷. Continuing with this rule, the optimal depth (per the ratio) will be 0.78ft, though this will be adjusted to fit the desired response. Assuming the use of 3/4" plywood, take 1.5" of each dimension to approximate the internal volume. This gives us: 22.5"x13.5"x7.86" or 1.38ft³. It should be noted that driver magnets and internal bracing will reduce this volume.

3.2 SPL

Normal: 75dBZ Rocking: 85dBZ (at 1 meter)

In any audio, recorded or live, there is a continuous dB level and a peak dB level, and the distinction between the two is very important. In recorded audio the continuous level is referred to as LUFS and is the integrated dB level below full scale over a set time. This is the base floor of an audio file. Peaks are

⁶ <https://atc.audio/professional/loudspeakers/scm45a-pro/>

⁷ Dickason, Vance, and Shannon Becker. *Loudspeaker Design Cookbook*. 7th ed. Peterborough, NH: KCK Media Corp., 2023.

immediate transient deviations from that floor and necessitate headroom to accommodate without distortion. Specific LUFS levels are determined by the transient/peak needs of the relative genre or platform. For example, Spotify requires an integrated level of -14 LUFS⁸, meaning the base audio must contain 14 dB of headroom for transient peaks. However, measuring your LUFS while working isn't always practical with only VU meters.

A system has been developed to fix these monitoring shortcomings while simultaneously unifying genre mastering. This is called the K-System. Instead of a meter referencing 0dB peak, this system uses 0dB as the reference loudness and extends its upper range to solely represent peak information⁹. This upper range varies depending on the use case, with K-20 having the most dynamic range of 20dB. If we use the K-system reference level of 83dB then we would need a system capable of producing 103dB peak. As a mixing monitor we'll use the highest dynamic range. This is more than enough to cover any musical streaming service currently available. Notably, Netflix and many physical film standards require around 25dB above the integrated level. If we wanted to include this range we'd need 108dB peak.

From personal research in listening, I have discovered that my nominal listening level is around 77dBZ at one meter, with my "rocking" level at 85dBZ. Using my higher listening level as a guide, I'd need my system to be capable of at least 85dB continuous and 110dB peak. Unfortunately, the table for this data was lost when my laptop broke. However, all measurements were done at one meter.

When selecting an amplifier, we must consider our peak value. For amplifiers, headroom is represented in dBW which is analogous to our dB value. With this we can then determine the required wattage to produce said volume with the inclusion of our speaker sensitivity. Speaker sensitivity is subtracted from the peak to represent the change in volume or "Gain" from one Watt. Generally, drivers in my price range of \$100-\$200 have a sensitivity of 89dB@1W,1m. Fortunately, my listening position is at one meter, so the gain does not need to be adjusted for distance. Here's how required Wattage is calculated:

$$\begin{aligned} \text{Gain} &= 110 \text{ peak} - 89\text{dB @1W, 1M} \\ &= 21\text{dB Gain} \\ 21\text{dB Gain} &= 10(\text{Log}_{10}(\text{Watts})) \\ &= 126 \text{ Watts} \end{aligned}$$

Here, amplification choices can go two directions. We can either meet the minimum by exceeding the wattage with a 150-Watt amplifier or barely undercut with a 125 Watt amplifier. A 125-Watt amplifier will get 99.5% of the job done for less cost, but might get strained with higher output over long periods. A 150-Watt amp will definitely get the job done always and will be strained less thermally but will cost more. It's also recommended that the amplifier have additional headroom above peak to prevent any early distortion. Thus, a 150-Watt minimum amplifier is recommended for this application. An important note is that this applies to an 8-Ohm load. To meet these requirements, the Fosi V3 stereo amplifier will be more than enough at 300watts per channel. This means the output should hover around 50%, limiting the possible distortion, something that happens at lower levels in low-end amplifiers.

⁸ <https://youlean.co/loudness-standards-full-comparison-table/>

⁹ <https://www.digido.com/portfolio-item/level-practices-part-2/>

3.3 Frequency Response

In short, these should be ruler flat. Across the nominal spectrum there should be deviation of less than +/- 1.5 dB up through 20kHz. Any breakup should lie beyond 20kHz or be crossed over. The entire system should represent 20Hz-20kHz with no coloration with an emphasis on clarity and transient response. The main boxes should play fully down to 80Hz at a minimum. Ideally down to 50Hz or 60Hz would allow for more flexibility in crossover points. The subwoofer should comfortably reach down to 20Hz, up to 100Hz available for crossover points.

4.0 Tweeter Comparison

	Size (in)	Dome Type (Material)	Short Term Power (W)	Long Term Power (W)	Sensitivity (dB@1W,1m)	Thermal SPL (dB)	Peak SPL (dB)	Nominal Impedance (Ω)	Rec. X-Over	Price	Free Air resonance
SEAS Prestige Titan 27TAC/GB	1"	Aluminum/Magnesium	240	180	89	111.55	112.80	6	1.8 kHz	\$92.50	830 Hz
Fountek NeoCd3.5H	3"	Ribbon/Horn	25	12	95.5	106.29	109.48	7	2.5 kHz	\$106.50	N/A
Seas Prestige H1280-06 22TFF	3/4"	Textile	180	90	91	110.54	113.55	6	2.5 kHz	\$55.30	1050 Hz
SB Acoustics SB26CDC-C000-4	1"	Aluminum/Ceramic	N/A	100	89	109.00	#VALUE!	4	2.6 kHz	\$61.40	690 Hz
SB Acoustics SB21SDC-C000-4	0.83"	Textile	N/A	40	91	107.02	#VALUE!	4	2.6 kHz	\$43.30	720 Hz
Morel MDT29 1" Textile Dome Tweeter	1"	Textile	1000	80	89	108.03	119.00	8	N/A	\$72.00	900 Hz
Peerless DA25TX00-08	1"	Corundum	N/A	100	88.7	108.70	#VALUE!	8	2 kHz	\$109.00	634 Hz
CSS LD25X-XBL2	1"	Silk	N/A	75	90	108.75	#VALUE!	8	N/A	\$193.27	865 Hz

Fountek Neo Cd3.5H Horn Tweeter¹⁰

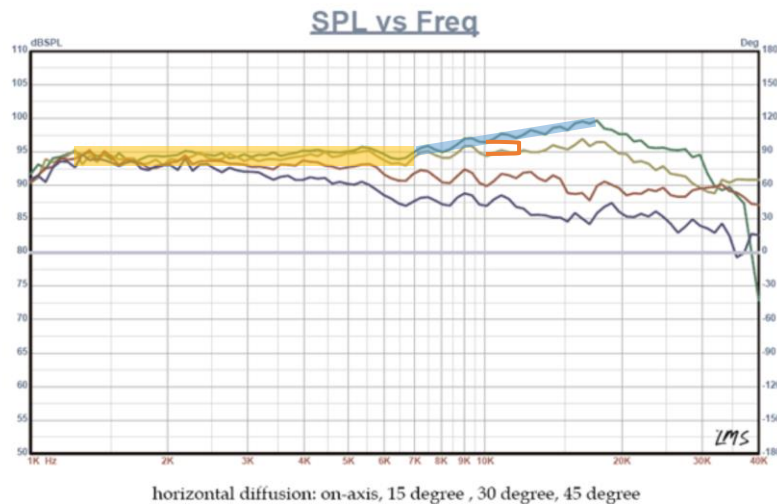

+/- 1.5dB from 1.2kHz to 7kHz

4dB/Octave Rise: +/- .75dB

-2.5dB: 15 degrees off-axis @ 10kHz

¹⁰ <https://www.madisoundspeakerstore.com/ribbon-tweeters/fountek-neocd3.5h-horn-tweeter/>

- This is a horn loaded ribbon driver. It has a surprisingly high output with only 12-Watt RMS Thermal power limits with a sensitivity of 95.5 dB@1W,1m. This allows for 106 dB SPL continuous power, 109dB peak. If listening at 77 dB at -27 LUFS (Netflix), this can comfortably support full dynamic range of any movie. If listening to music at 85 dB at -16 LUFS (Apple Music)
- It Possesses the benefits of many ribbon tweeters: extremely low distortion and wide horizontal spread. This spread pairs well with the vertical MTM driver configuration which emphasizes horizontal coverage. Horizontal diffusion is symmetrical from 1kHz to 20kHz up to 45 degrees off axis. Additionally, ribbon tweeters have a transparent and airy sound which helps remove the speaker from the music. This is supported by reviews of the driver.
- High frequency extension and breakup above 20kHz. This is also quite low reaching for a ribbon with a solid response down to 1kHz. This makes it ideal for a 2-way crossover at 2kHz or higher.
- Frequency response is +/-1.5dB from 1.2kHz to 7kHz. It has a consistent rise of 4dB/Octave which contributes to a smile curve if left stock; but it could also be easily corrected with a gentle slope via DSP. Horizontally, you lose only 2 dB at 10kHz, 15 degrees off axis; or about -7dB at 45 degrees. Overall this can become a very flat, wide-range ribbon tweeter with very low distortion, transparent sound, and wide sound stage.
- Visually, I love the look of horns AND ribbon drivers so this is a win-win.
- Note: This is a large tweeter configuration spanning 4.33" tall.

SB Acoustics SB21SDC-C000-4¹¹



+/- 1dB
from 1kHz
to 20kHz

-2dB:
30 degrees off-
axis @ 10kHz

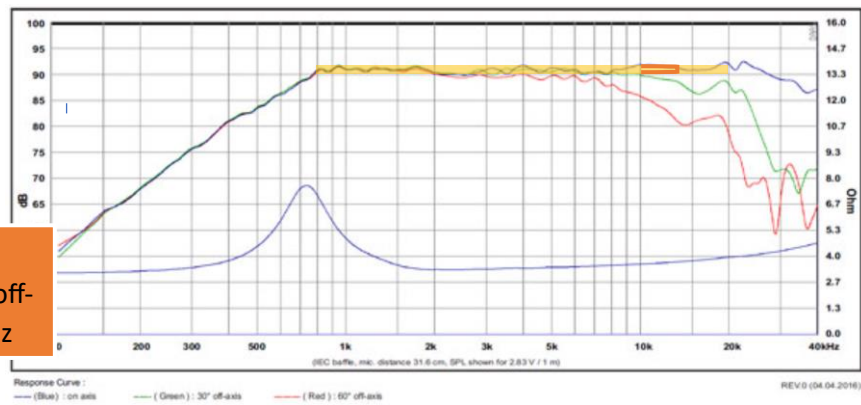

¹¹ <https://sbacoustics.com/product/sb21sdc-c000-4/>

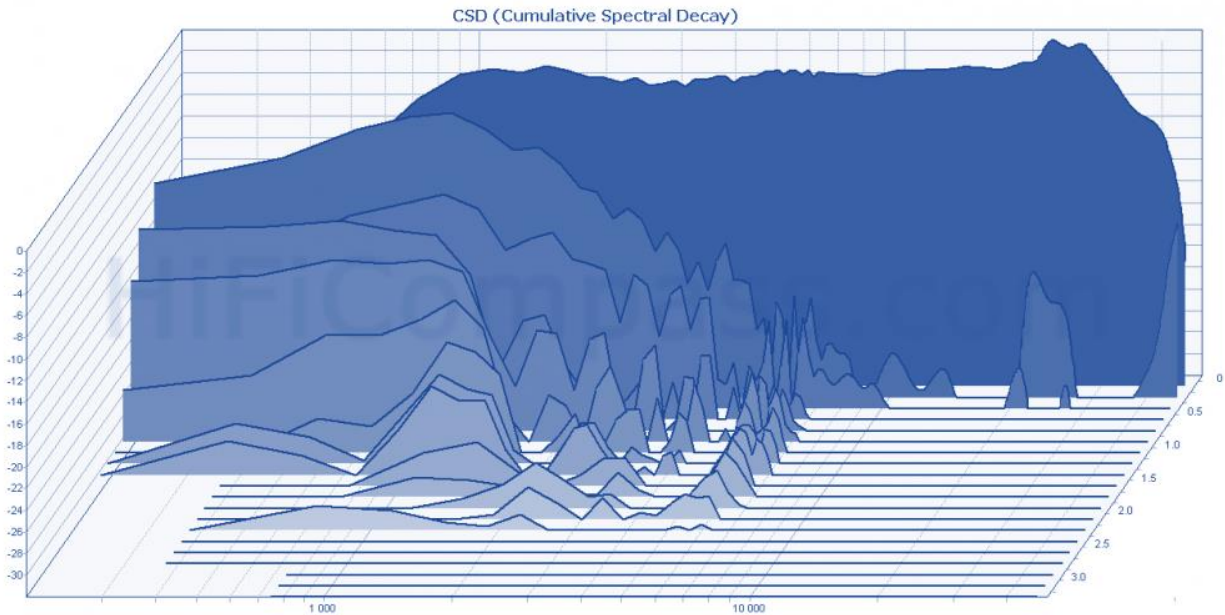

- This tweeter is extremely surprising. Starting off strong, it has a sensitivity of 91dB @1W,1m, allowing this driver to reach 107dB, again more than enough to support the full dynamic range of film standards at the desired listening level; also supports all musical loudness standards at up to 90dB before thermal limit.
- What really drew me to this driver was the frequency response: +/- 1dB from 1kHz to 20kHz. At the price of \$43 dollars this is remarkable and an easy choice for a budget build. Paired with a 91dB sensitivity this is an extremely competitive option. Further, the impedance response is smooth and quite gradual from 2kHz to 20kHz, likely to the flat frequency response.
- The horizontal diffusion is comparable to a ribbon tweeter, losing only 2dB at 10kHz and a gentle roll-off to 20kHz where there is only a 5dB reduction at 30 degrees off axis. While no reviews speak to the driver's transparency, the off-axis response creates a wide and accurate sound stage, broadening the listening sweet-spot.
- Looking at the waterfall we can see that the response is very tight, with little lingering resonances, most of which would be cutoff with a 2kHz or higher crossover.
- I love the inset look of these, though beyond that they follow the standard black dome tweeter look
- Going with this tweeter would be a great option to free up budget elsewhere in the build. More could be put towards higher quality woofers or cleaner amplifiers.
- These are the most likely choice as of 10/9/23

CSS LD25X-XBL2¹²

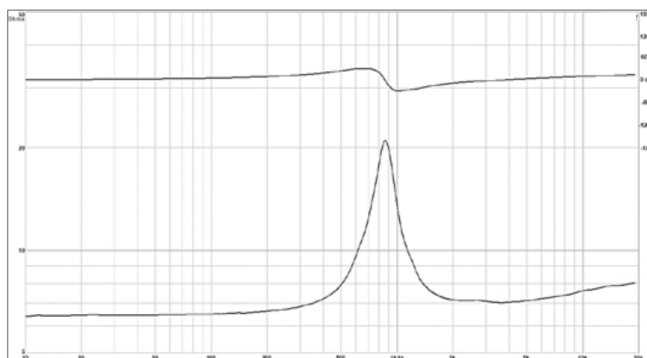
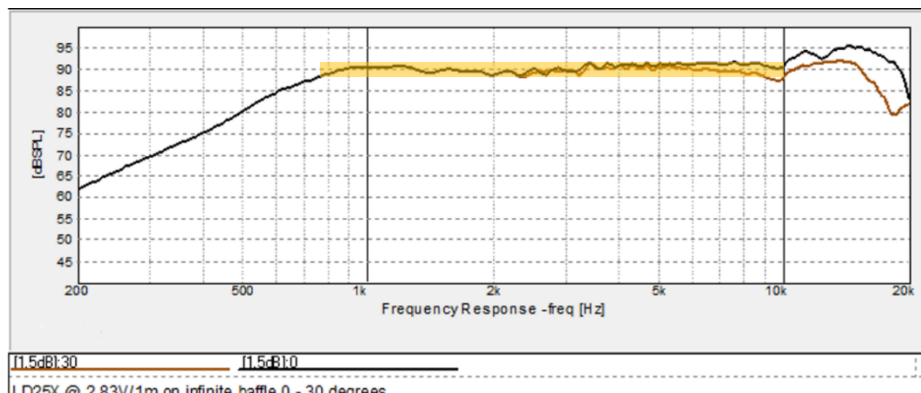

- This tweeter is a direct competitor with the SB21SDC above, presenting with slightly lower sensitivity of 90dB and a maximum thermal SPL of 108dB requiring more power. The max thermal SPL covers the needs of cinematic and musical standards at the desired listening levels.
- Looking at frequency response, it varies a bit more at +/- 1.5dB from 750Hz to 10kHz, with a boost between 10kHz and 20kHz; it's questionable how flat this can get with DSP correction.
- The impedance response also deviates further, with noticeable lumps past 2kHz. Notably, the resonant frequency is higher as well. The impedance and frequency response make me question why these are 3X the cost of the SB Acoustic tweeter. Reviews suggest this tweeter provides a deeper and more transparent image than comparable textile dome tweeters. Looking at the off-axis response shows a much stronger response above 10kHz, following the on-axis response and meeting it again at 20kHz.
- Compared to the SB Acoustics tweeter these are: 1-2dB louder, require more power, are 3X the cost, and vary more in frequency. However the off axis response follows the on-axis much higher. In conclusion, the reasons for choosing these do not lie in these data as their quality is tied to depth and transparency. Unfortunately, cost prohibits trial runs.

¹² <https://www.css-audio.com/online-store/CSS-LD25X-XBL%5E2-25-mm-Silk-Dome-Tweeter-p144557321>

Tweeter Selection

After reviewing the data for these tweeters, I decided to go with the Fountek Neo Cd3.5H. The first reason I chose this driver is performance vs cost. As a ribbon tweeter, this driver extends surprisingly low, offering a great deal of flexibility when choosing a crossover frequency. It offers all of the benefits of a ribbon tweeter as well: controlled vertical spread with wide horizontal spread (pairing the MTM design), strong high frequency extension to 30kHz, wide soundstage, depth, and transparency of sound. All of these are design aspects I hope to incorporate into my speaker. For \$100, this quality of ribbon tweeter is very rare. Second, the frequency response of this tweeter is very flat with a linear boost of 10dB from 7kHz to around 17kHz, which can be left untouched for a natural smile curve, producing a more exciting sound. As a linear rise, this will be very easy to EQ flat in tuning. The only foreseeable issue with this driver is flush mounting to the front baffle. As a complex rounded square, routing a perfect shape will be quite difficult and require the use of a custom jig.

5.0 Woofer Comparison

	Nominal Size (in)	Cone	Price	Sensitivity	Power	Thermal SPL Limit	Mechanical SPL Limit	X-max	Sd cm ²	Vas (liters)	Qts	Fs	Vb (liters)	Vb (cu feet)	Vd	F3	X-max SPL	K1	Website	Colloms Wmax	colloms
Audax HM170Z18	6.5	Aerogel	\$156.90	89.3	60	107.1		3.25	214.1	35.39	0.34	38.9	20.13	0.71	0.0001	49.9	113.4	0.00000	94.4	0.1	110.95
Eton 7-212/C8/32 Hex Symphony II	7	Hexacone	\$185.00	89	80	108.0		8.8	248.3	26	0.32	38	12.11	0.43	0.0002	53.2	114.1	0.00000	96.2	1.1	112.06
SEAS Prestige CA18RLY	7	Paper	\$109.80	90	80	109.0		10	248.3	32	0.47	42	52.98	1.87	0.0002	33.6	113.4	0.00000	96.4	0.2	111.37
SEAS Prestige L18RNX/P	7	Aluminum	\$116.00	88	100	108.0		11	248.3	30	0.31	36	12.58	0.44	0.0003	52.8	114.2	0.00000	96.6	1.7	112.24
Dayton Audio RS180-8	7	Aluminum	\$69.98	87.1	60	104.9		6	248.3	24.4	0.31	35.7	10.23	0.36	0.0001	52.3	113.9	0.00000	95.5	0.5	111.70
SEAS Prestige U16RCY/P	6	Woven Polypropylene	\$122.30	87	60	104.8		10	182.4	25	0.32	36	11.64	0.41	0.0002	50.4	113.8	0.00000	96.2	0.6	111.81
CSS LDW7	7	Paper/Fiberglass	\$161.00	86.8	80	105.8		5.5	248.3	31.2	0.38	31	25.61	0.90	0.0001	33.8	113.1	0.00000	95.4	0.1	110.86

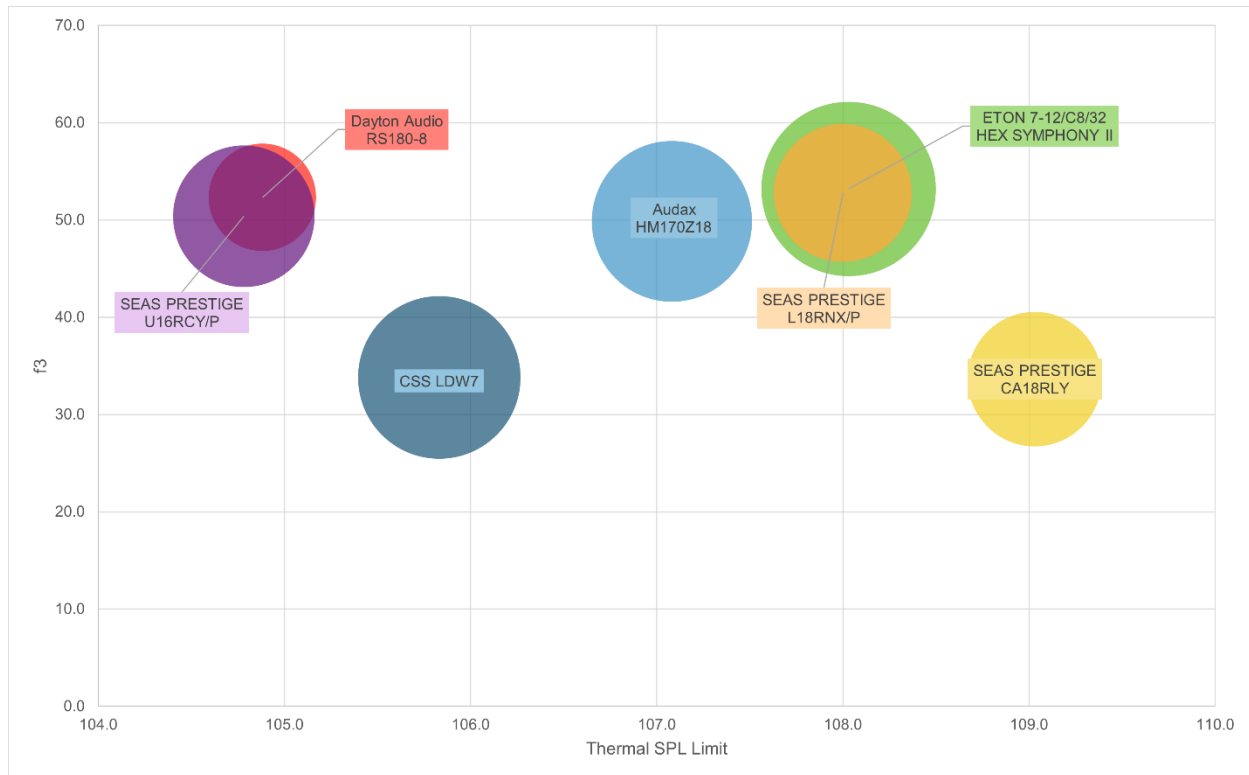

In this plot, the vertical axis represents the F3 of the drivers, where the low end begins to roll off. The horizontal axis represents the thermal power handling of the driver. The size of the circle represents the cost of the driver.

Audax HM170Z18¹³

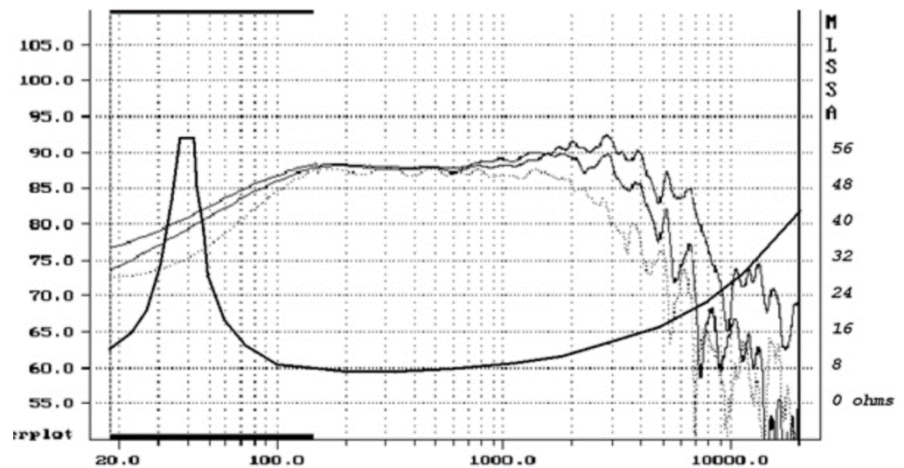

- This is a very unique driver as the cone features a new type of material called Aerogel. Aerogel is the lightest solid material known to man, comprised of 99.9% air. This means the cone of the driver is extremely light, which would translate into very fast impulse response and low amounts resonance. Looking at the impedance plot, we can see that the response is very smooth, although the graph might be smoothed by looking at the sharp angle changes in the slope. This driver is flat from around 105Hz to around 1kHz. Unfortunately, the driver looks to break up fairly quickly above 1kHz, which isn't necessarily represented by the impedance plot. With the Fountek ribbon tweeter, I will need a much more linear response up to 3kHz for the crossover, something this driver would struggle with. Additionally, this driver has a fairly high F3, meaning the bass response of my speakers would fall off much earlier than I want in a full spectrum system.
- This driver does have fairly high power handling at a thermal limit of 108dB. It also features a phase plug, improving the linearity of the cone through impulses. The off axis response is also very good, with around a 3dB drop off starting at 1.1kHz
- The cost of this driver is also fairly high for the projected performance. At \$156 I cannot justify using this driver in a 2-way system. However, I could see this driver working very well as part of a 3-way system, if a smaller mid-woofer was used to fulfill the upper midrange this driver fails to produce linearly. It's clear that you're paying for the new space-aged material used in the cone, which doesn't seem to translate into spectacular performance. Additionally, aerogel is extremely brittle, meaning the cone is subject to easy damage, which is an important consideration to make considering the speakers will live in a semi-public space during the testing phase.

¹³ <https://www.madisoundspeakerstore.com/audax-woofers-6-7/audax-hm170z18-6.5-woofer-aerogel-cone/>

Seas Prestige CA18RLY¹⁴

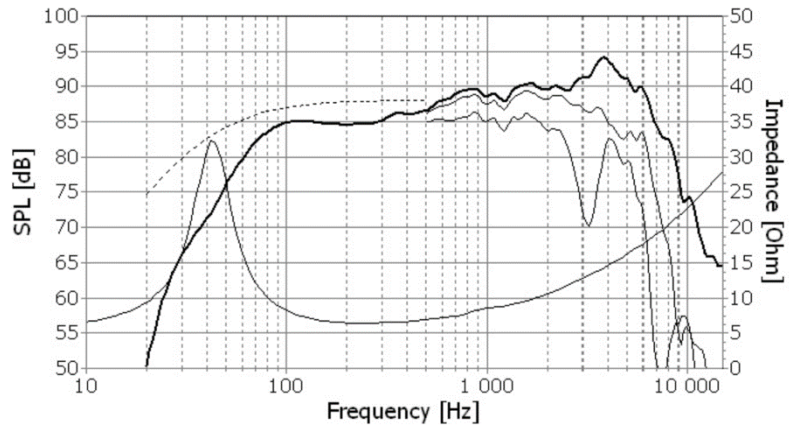

- This driver from Seas offers great power handling for a good price. For \$109 you get 109dB of thermal power handling (\$1 per dB), the highest of the collected driver selection. You also get a low F3 of 33.6Hz. So, in short, this driver is the loudest and the lowest, all for a very reasonable price.
- Where this driver begins to diminish in quality is around 500Hz, with an inconsistent rise past that, which would make a flat EQ somewhat troublesome. Again, this driver would not mesh well with the selected Fountek ribbon tweeter as it needs a flat response to at least 2.5kHz. This would place the crossover point at the most troublesome point in this driver's frequency response, making a flat transition between the woofer and the tweeter difficult to resolve.
- Here, you're paying for power handling capabilities of the driver, something I don't necessarily need at my desired listening levels. With a mountainous frequency response, the cost would be misplaced as a driver selection.
- Horizontal off axis performance seems to be very good through 1.2kHz, but deviates significantly past that. In the MTM design, I'm looking for very close off axis response to match the desired horizontal spread and width of listening position. Already in the MTM design the vertical listening position is limited. If this driver was selected, the horizontal spread of the tweeter and woofer would be mismatched, causing inconsistent off axis response through the entire system. With this driver, the overall spread of the speaker would be very directional, something I do not necessarily want in the horizontal spread. This would also cause some unpredictable reflections off the side walls surrounding the listening position.

¹⁴ <https://www.madisoundspeakerstore.com/seas-woofers-6-7/seas-prestige-ca18rly-h1217-7-coated-paper-cone-woofer/>

CSS LDW7¹⁵

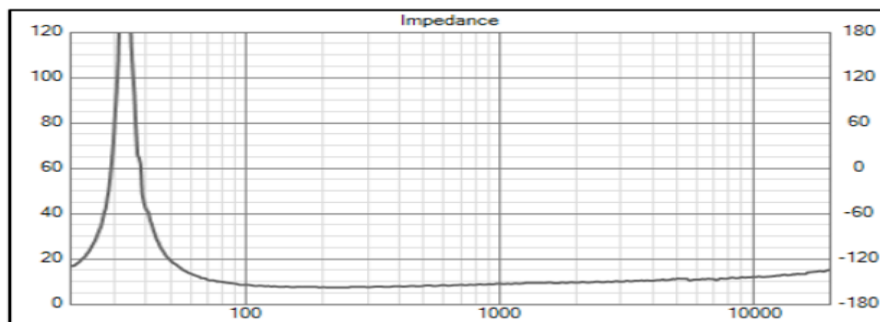
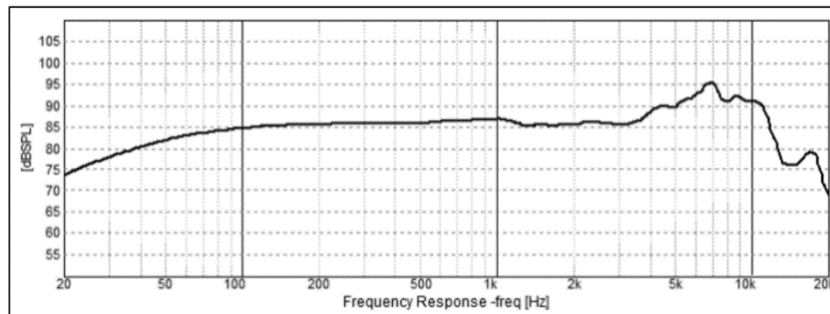

- The defining feature of the CSS LDW7 is its wide linearity. Looking at the graph is almost ruler flat from 100Hz right up to 3kHz. Already this looks like a perfect pair for the Fountek ribbon tweeter. With a very flat and wide response, the crossover frequency has a lot of flexibility, making it much easier to implement into the system. Additionally, because of its linearity, there should be minimal EQ to achieve a flat response, reducing potential phase issues.
- This driver also has very low distortion, contributing to a very clean reproduction of signal, resulting in a natural and accurate sound. Looking at the impedance response we can see that the resonant frequency of the driver is exceedingly low, meaning the resonance of the driver should not interfere with its performance, contributing to its low distortion. Past that the curve is very smooth, with a slight fluctuation around 5kHz, well above the anticipated crossover frequency.
- Finally, this driver has almost all five star reviews from multiple websites. These reviews cite impressive clarity and bass extension, punching well above their price tag. The only real negative with this driver is the lower sensitivity. As described earlier, my listening level is a bit lower than typical meaning a lower output doesn't much affect my decision on driver choice. This is especially true when I'll have two of them set up in an MTM.
- The price tag on these is a little steep, costing \$161 each, for a total of around \$700 dollars. However, the reviews convince me the quality of these drivers is well worth the extra cash.

¹⁵ <https://www.css-audio.com/online-store/CSS-LDW7-7-Midwoofer-p110079914>

Box Simulation

The box design process starts with WinSpeakerz, a speaker box design software for Windows. This is used to simulate the response of my selected drives in a given enclosure. It allows us to determine the low end curve and bass response we can get out of our drivers. This aids in the selection of a final driver as it tells us the response we'll get. The first step in WinSpeakerz is to input your driver T/S parameters including:

- Nominal Diameter – D
- Nominal Power – P
- Sensitivity – SPL
- Free Air Resonance – F(s)
- Total Q – Q(ts)
- Electrical Q – Q(es)
- Mechanical Q – Q(ms)
- Equivalent Volume – V(as)
- Nominal Impedance – Z
- DC Resistance – R(e)
- Max Thermal Power – P(t)
- Max Linear Excursion – X(max)
- Number of drivers – N
- Input Power – P(in)

With the driver information ready, the next step is to start to edit the box parameters to find your desired response curve. It's important to note that this simulation only works with woofers. We do not model tweeters! From my functional description, I know that I want a flat response with good bass extension, but low end F3 is flexible as this system is intended to be used with a subwoofer. In playing with the parameters, and through research, we find that we can get bass extension from the addition of a port, also known as a vented enclosure. This also gives me more power handling as the port will add to the power of our overall response.

In the box parameters, we can edit the box volume, resonant frequency, and Q to achieve our desired curves. You can also change the enclosure to between a vented and sealed box. There are three basic curves we can try to hit per box type (sealed vs vented).

For a sealed enclosure you can target a bass boost with a Q of 1.2, flat with a Q of 0.707, and a gradual low end roll off with a Q of 0.5. In modeling the sealed box, you should only edit the Q parameter or the box volume. As we are modeling target curves, the Q of each curve is predetermined for a sealed enclosure, meaning you can tell the software what Q you want, and it will spit out a volume to simulate that response based on your driver parameters.

This works differently for vented enclosures. When modeling a vented box, you can edit box volume and the resonant frequency, vent surface area, and vent length. The Q is only applicable for a closed box. The target curves for a vented box are a bass boost, flat, and a low shelf and do not have predetermined Q. To achieve these curves, you will edit the box frequency and volume, going between the two to

simulate an appropriate response. This will take much more time as the shape of the curve is dependent on those two factors instead of the single Q.

With this I modeled a few of my selected drivers to see how they compare. Below are the simulation results for those drivers. While I simulated each driver to hit a variety of target curves, I knew that I wanted a flat vented box, so that is what is displayed below.

Audax HM170Z18

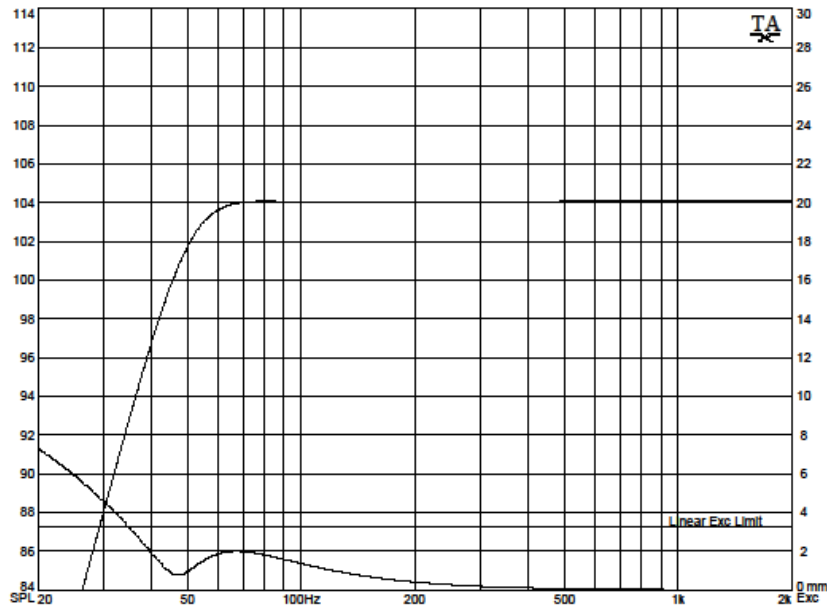

Driver Parameters

Driver:	Audax HM170Z18
Nominal Diameter	D = 6.5 in
Nominal Power	P = 0 Watts
Sensitivity (1W/1m)	SPL = 89.3 dB SPL
Free Air Resonance	f(s) = 38.9 Hz
Total Q	Q(ts) = 0.34
Electrical Q	Q(es) = 0.38
Mechanical Q	Q(ms) = 4.07
Equivalent Volume	V(as) = 1.25 cu ft
Nominal Impedance	Z = 0 Ohms
DC Resistance	R(e) = 0 Ohms
Max Thermal Power	P(t) = 60 Watts
Max Linear Excursion	X(max) = 3.25 mm
Max Excursion	X(lim) = 0 mm
Voice Coil Diam.	D(vc) = 0 mm

Driver Notes:

NOTE: X(max) was estimated based on the nominal driver diameter.
 NOTE: S(D) was estimated based on the nominal driver

System Notes:

Box Parameters

System Type:	4th Order Vented Box
Box Volume	V(B) = 1.5 cu ft
Closed Box Q	Q(tc) = 0.5552
Box Frequency	F(B) = 47 Hz
Min Rec Vent Area	S(vMin) = 4.66 sq in
Vent Surface Area	S(v) = 0 sq in
Vent Length	L(v) = 0 in
Compliance Ratio	alpha = 1.667
Box Loss Q	Q(B) = 7

System Parameters

No. of Drivers	N = 2	
Isobaric Factor	I = 1	(1=normal, 2=iso)
Input Power	P(in) = 15	Watts
SPL Distance	D = 1	m

My Company	
United States	248-770-5188
System Name:	
4th Order Vented Box	
Designer:	Spencer Beasley
Title:	Designer
Rev Dates:	Rev:

Dayton Audio RS180-8

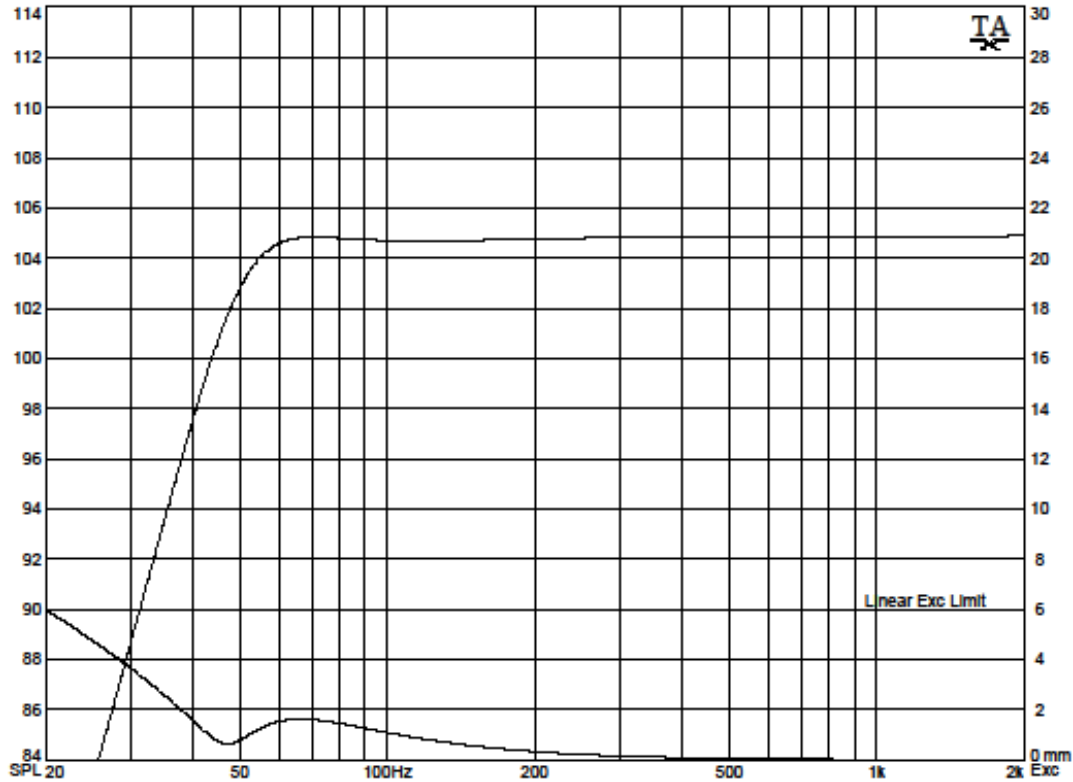

Driver Parameters

Driver:

Nominal Diameter	D = 7	in
Nominal Power	P = 0	Watts
Sensitivity (1W/1m)	SPL = 87.1	dB SPL
Free Air Resonance	f(s) = 35.7	Hz
Total Q	Q(ts) = 0.31	
Electrical Q	Q(es) = 0.42	
Mechanical Q	Q(ms) = 1.22	
Equivalent Volume	V(as) = 0.88	cu ft
Nominal Impedance	Z = 0	Ohms
DC Resistance	R(e) = 0	Ohms
Max Thermal Power	P(t) = 60	Watts
Max Linear Excursion	X(max) = 6	mm
Max Excursion	X(lim) = 0	mm
Voice Coil Diam.	D(vc) = 0	mm

Driver Notes:

NOTE: Reference Efficiency was calculated based on the 1W/1m sensitivity.

NOTE: S(D) was estimated based on the nominal driver

System Notes:

Box Parameters

System Type: 4th Order Vented Box

Box Volume	V(B) = 0.9	cu ft
Closed Box Q	Q(tc) = 0.5289	
Box Frequency	F(B) = 47	Hz
Min Rec Vent Area	S(vMin) = 10.4	sq in
Vent Surface Area	S(v) = 0	sq in
Vent Length	L(v) = 0	in
Compliance Ratio	alpha = 1.911	
Box Loss Q	Q(B) = 7	

System Parameters

No. of Drivers	N = 2	
Isobaric Factor	I = 1	(1=normal, 2=iso)
Input Power	P(in) = 30	Watts
SPL Distance	D = 1	m

My Company	
United States	248-770-5188
System Name:	
4th Order Vented Box	
Designer: Spencer Beasley	
Title: Designer	
Rev Date:	Rev:

Eaton 7-212 Symphony II

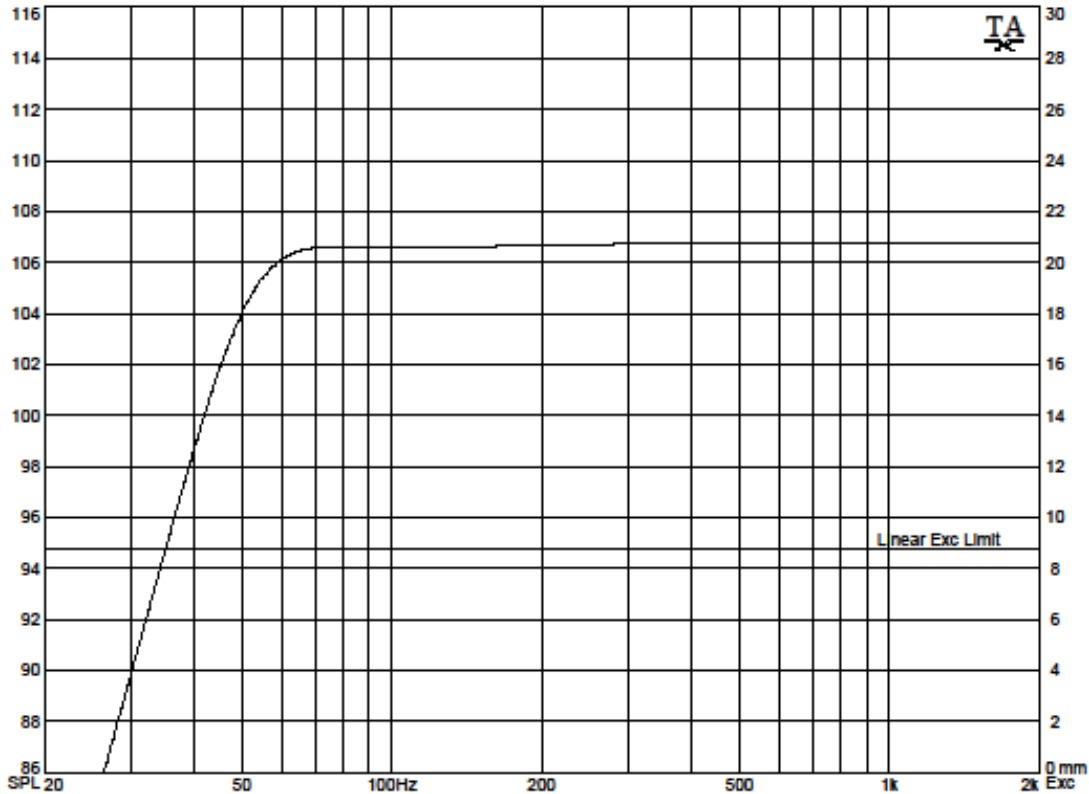

Driver Parameters

Driver:

Nominal Diameter	D = 0	in
Nominal Power	P = 0	Watts
Sensitivity (1W/1m)	SPL = 89	dB SPL
Free Air Resonance	f(s) = 38	Hz
Total Q	Q(ts) = 0.32	
Electrical Q	Q(es) = 0.34	
Mechanical Q	Q(ms) = 5.61	
Equivalent Volume	V(as) = 0.92	cu ft
Nominal Impedance	Z = 0	Ohms
DC Resistance	R(e) = 0	Ohms
Max Thermal Power	P(t) = 80	Watts
Max Linear Excursion	X(max) = 8.8	mm
Max Excursion	X(lim) = 0	mm
Voice Coil Diam.	D(vc) = 0	mm

Driver Notes:

NOTE: Reference Efficiency was calculated based on the 1W/1m sensitivity.

System Notes:

Box Parameters

System Type: 4th Order Vented Box

Box Volume	V(B) = 1	cu ft
Closed Box Q	Q(tc) = 0.5408	
Box Frequency	F(B) = 48	Hz
Min Rec Vent Area	S(vMin) = 0	sq in
Vent Surface Area	S(v) = 0	sq in
Vent Length	L(v) = 0	in
Compliance Ratio	alpha = 1.856	
Box Loss Q	Q(B) = 7	

System Parameters

No. of Drivers	N = 2	
Isobaric Factor	I = 1	(1=normal, 2=iso)
Input Power	P(in) = 30	Watts
SPL Distance	D = 1	m

My Company	
United States	248-770-5188
System Name:	
4th Order Vented Box	
Designer: Spencer Beasley	
Title: Designer	
Rev Date:	Rev:

CSS LDW7

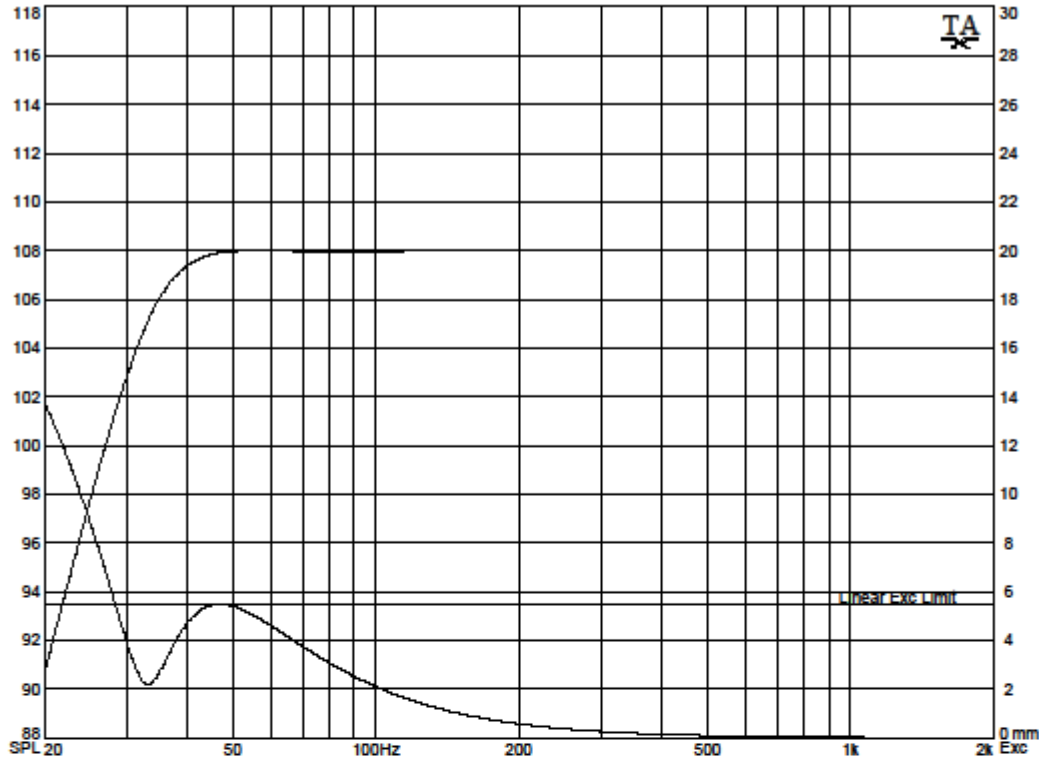

Driver Parameters

Driver:

Nominal Diameter	D = 7	in
Nominal Power	P = 80	Watts
Sensitivity (1W/1m)	SPL = 86	dB SPL
Free Air Resonance	f(s) = 30	Hz
Total Q	Q(ts) = 0.37	
Electrical Q	Q(es) = 0.39	
Mechanical Q	Q(ms) = 9	
Equivalent Volume	V(as) = 1.095	cu ft
Nominal Impedance	Z = 8	Ohms
DC Resistance	R(e) = 6.4	Ohms
Max Thermal Power	P(t) = 80	Watts
Max Linear Excursion	X(max) = 5.5	mm
Max Excursion	X(lim) = 0	mm
Voice Coil Diam.	D(vc) = 0	mm

Driver Notes:

NOTE: Reference Efficiency was calculated based on the 1W/1m sensitivity.

System Notes:

Box Parameters

System Type: 4th Order Vented Box

Box Volume	V(B) = 1.7	cu ft
Closed Box Q	Q(tc) = 0.5596	
Box Frequency	F(B) = 33	Hz
Min Rec Vent Area	S(vMin) = 5.9	sq in
Vent Surface Area	S(v) = 5.9	sq in
Vent Length	L(v) = 6.621	in
Compliance Ratio	alpha = 1.288	
Box Loss Q	Q(B) = 7	

System Parameters

No. of Drivers	N = 2	
Isobaric Factor	I = 1	(1=normal, 2=iso)
Input Power	P(in) = 80	Watts
SPL Distance	D = 1	m

My Company	
United States	248-770-5188
System Name:	
4th Order Vented Box	
Designer:	Spencer Beasley
Title:	Designer
Rev Date:	Rev:

Woofer Selection

My final selection for the woofer in this MTM setup will be the CSS LDW7. With its low distortion and bass extension these will have an impressive sound quality and range. Through the simulations we can see that the CSS LDW7 offers the best bass extension. Additionally, they are flat from 100Hz to 3kHz, allowing a great deal of flexibility in crossover points with the Fountek ribbon tweeter. While they are a bit pricy, reviews reassure me that they are worth the cost in quality.

Amplifier Selection

For amplifiers I decided to go with two Fosi Audio V3¹⁶ stereo amplifiers. These offer great performance for the price, producing 300-watts per channel with a very clean sound. With a price of \$89 these should be a great choice for my system.

DSP Selection

For DSP I decided to go with the Dayton Audio 4x8 DSP¹⁷. The other choice here was MiniDSP. While the MiniDSP might have a superior user interface, build quality, and sound quality, they are almost 2x the cost of the Dayton Audio DSP, which provides the same basic functionality with double the inputs and outputs. This enables greater flexibility in future implementation of new system components like my subwoofer or potentially a surround system.

6.0 Box Design

Now that I have selected drivers and a box volume/resonance that are suitable for my needs I can begin shaping the dimensions of the box to fit my desired aesthetic and performance. I started this process by throwing my tweeter and woofers into AutoCAD to begin designing the layout, specifically driver separation. In an MTM design, the closer the two mid-woofers are to each other, the lesser the off-axis comb filtering. However, the distance between the woofers must also support the large 4" Fountek ribbon tweeter, as well as maintaining visually appealing separation. With this in mind, I found a suitable layout that has a small enough separation between drivers but is nice to look at:

¹⁶ https://www.amazon.com/dp/B0C36S8DCT/ref=pe_386300_440135490_TE_simp_item_image

¹⁷ <https://www.parts-express.com/Dayton-Audio-DSP-408-4x8-DSP-Digital-Signal-Processor-for-Home-and-Car-Audio-230->

500?quantity=1&utm_source=google&utm_medium=cpc&utm_campaign=18197889536&gad_source=1&gclid=CjwKCAiA1fqrBhA1EiwAMU5m_zWwT-0YyIHLLvwJTKYd_XgQKkxglv1cIK_B51ViABkSZMqEtRJD6xoCYcwQAvD_BwE

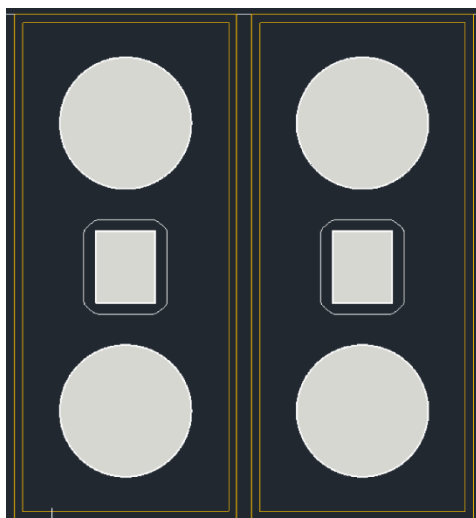

Originally, I wanted the height to width ratio to be a dissonant ratio of 2.6:1 to eliminate potential resonances inside the box. However, with a maximum height of 2ft, this meant that the width of the box would be too small for the 7" woofers, and it would just look too skinny. After playing with the front baffle size, I found a ratio that fit the woofers but was also close to the target of 2.6:1. This resulted in an outer dimension of $24 \frac{1}{4}" \times 10 \frac{1}{4}"$ for a ratio of 2.4:1. It's important to note that this is the external size and does not represent the internal volume, meaning additional thickness of the material must be subtracted from each dimension. For this build I plan to use $\frac{3}{4}"$ plywood, so a total of 1.5" must be subtracted from each dimension to achieve the proper volume. The internal dimensions of the front of the box are $22.5" \times 8.75"$.

With my front baffle designed, I then went back into Winspeakerz to design the full box proportions. Since I already knew the height and width I needed, the only dimension left to find was the depth. Before finding the depth, I first input the driver displacement, which changes the gross internal volume of the box. This needs to be included to get an accurate representation of the box with the drivers installed. Interestingly, I found that the volume of the Fountek ribbon tweeter was greater than the volume of the CSS woofer magnet (the general volume used to represent the woofer displacement). The next step is to calculate the depth.

In Winspeakerz you can lock one dimension, input another, and it will auto calculate the last remaining dimension based on your desired internal volume. Here, I locked the height, input the width, and it gave me the depth (to achieve a gross internal volume of 1.7 cu ft). With the full internal dimensions, I went back into AutoCAD and began designing the rest of the box. Note that this will not be the final depth as I first have to design the internal bracing. The additional material used in the bracing will change the gross volume, thus changing the calculated depth.

I wanted to use bracing to improve the rigidity of the box and further prevent resonant buildup. This was especially important as I could not perfectly achieve my desired dissonant height to width ratio.

There were several bracing options to choose from: corner bracing, cross bracing, and shelf bracing¹⁸. I decided to use shelf bracing as it offers the most support between four surfaces. This is also called horizontal bracing as it is essentially a piece of wood slotted in like a shelf. What makes this effective is that it offers support between the front, back, and both sides with a single piece. While it's harder to install, it will be well worth the effort to dampen the box. Additionally, it would be impractical to use a solid piece of wood, as it would separate the enclosure into two separate boxes. To counter this, I designed large holes in the bracing to allow free flow of pressure while being sure not to make the wood too thin as to diminish its rigidity and support. To add even more rigidity, I designed the bracing to slot $\frac{3}{8}$ " into the box with a dado joint. Further, I designed the box to use two of these, each sitting between a woofer and the tweeter. This places each joint near the middle of the vertical dimension, the largest dimension with the most potential for deformation.

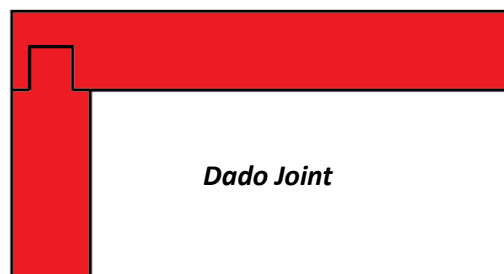

When I finished the design of the bracing, I went back into Winspeakerz and added the final volume component of bracing displacement. As this bracing goes between the front and the back, the depth of the brace must change to extend to a new depth. However, changing the depth of the brace changes its displacement, which changes the depth again. Here, a compromise must be made, or the volume calculation will go back and forth forever. In the end, I used the original displacement of the brace and ate the small amount of extra volume it created through the extension. At such a small volume the effects will be negligible. This resulted in a final box depth of 15.514".

With the external and internal dimensions of the box finalized, I then began to design how the panels will join together. In speaker design, the tighter the joint the less likely leaks are. Here, rabbit joints are a natural solution as they're easy to make and offer a great seal. In order to keep the box dimensions, the panels must be specially designed to support the rabbit joint, meaning that panels will overlap if comparing to the traditional T-joint. Additionally, properly determining the fitment of each panel will reduce the work load during the build process.

¹⁸ Dickason, Vance, and Shannon Becker. *Loudspeaker Design Cookbook*. 7th ed. Peterborough, NH: KCK Media Corp., 2023.

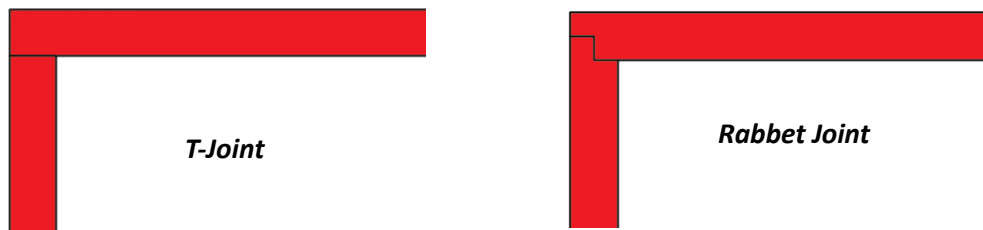

To properly design the rabbet joints, I started with simple T-joints to decide which panels will overlap the others. In my design, I have the front baffle sandwiched between the top and bottom. Then, the side panels fill in, being surrounded by the top, bottom, front, and back. The top and bottom will extend the depth of the box and are the only panels whose edges will be visible. From the dimensions, I knew that the side panels would be the largest, so they needed the most support. Being compressed on all sides means that any leakage would be prevented. From the T-joints, I then resized my panels and added the rabbet joints as shown in the image above.

The next step is to calculate my port. From the simulation, we are given a nominal port surface area to achieve the desired box resonance, but this rarely translates into a purchasable component. Instead, you can input your purchased port surface area (as close to nominal as possible) and Winspeakerz will calculate the length you need. I found that a 3" diameter port is closest to the nominal surface area, giving a calculated length of 8.142". I chose a circular port as it offers the smoothest airflow and largest availability of purchase selection. With the port size and length, I then went online to search for a 3" diameter port. I ended up choosing a flared port to aid in volume coupling and reduce any restriction of airflow. That port requires a 6.25" diameter hole to fit the flair.

In AutoCAD, I then add the holes for my tweeter, woofers, and port, as well as their mounting depth for a flush fit. This is the completed the design of the speaker:

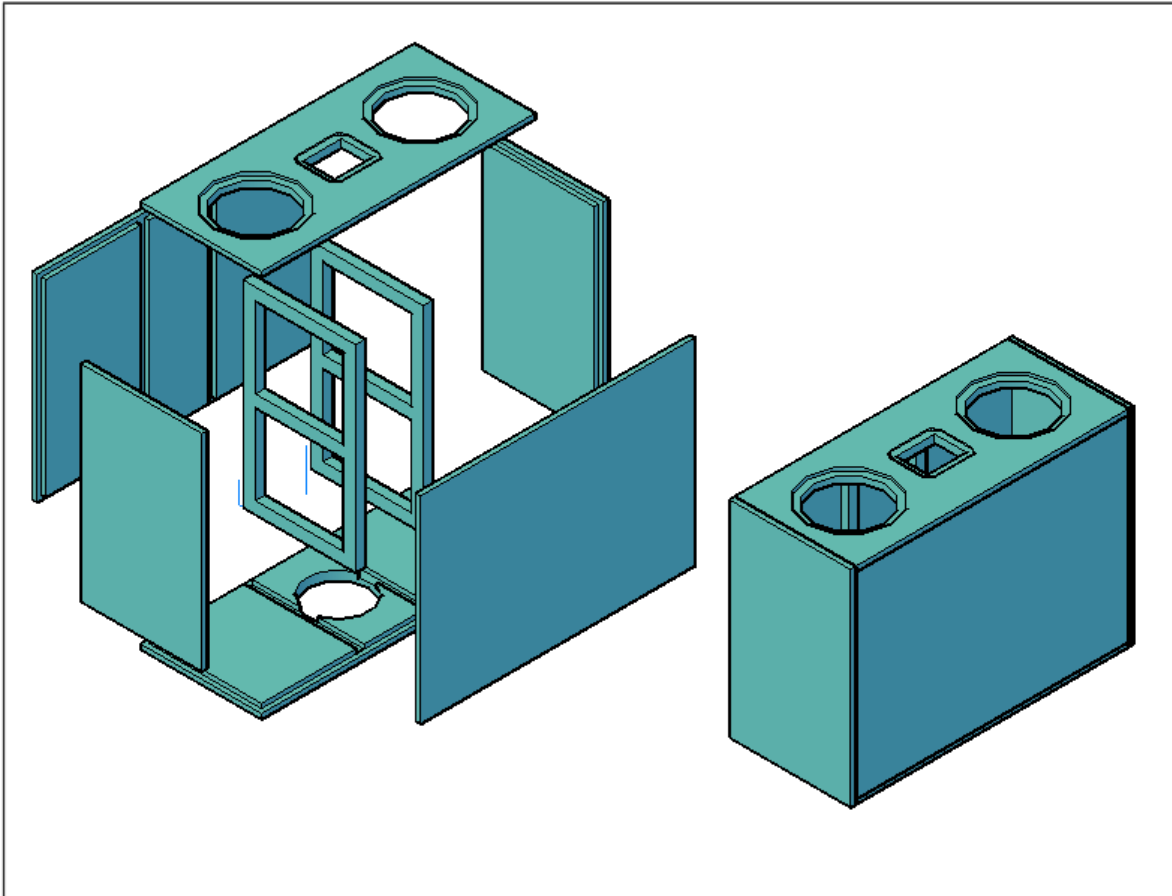

3D Conceptual View

Next, I laid out the panels to be cut. I knew that I would be constructing the cabinets out of $\frac{3}{4}$ " plywood, which typically comes in a 4ft x 8ft sheet, so I positioned the panels to fit this. I started by drawing out the plywood sheet in AutoCAD, then orienting the panels to fit as best as possible. The goal here is to minimize the amount of wood needed to construct the boxes, so I needed to position each piece properly to achieve this. Additionally, the panels should be oriented to minimize the number of cuts and make the build process more efficient, meaning like dimensions should align with each other. The internal bracing must also be included in this. Fortunately, I was able to position each panel so that both boxes could be built using a single plywood sheet, while reducing the number of cuts. This keeps cost down and makes moving materials a bit easier. The final cut sheet can be seen below. Also included in this sheet are the all-important dimensions, creating a guide for when I move into the workshop. More specific designs at the front end make for a much easier and more enjoyable build process.

used the AutoCAD drafting as a guide in creating this. This was also a test to see how I might want the outer physical appearance to look once built, guiding me in my wood choices to get a nice finish.

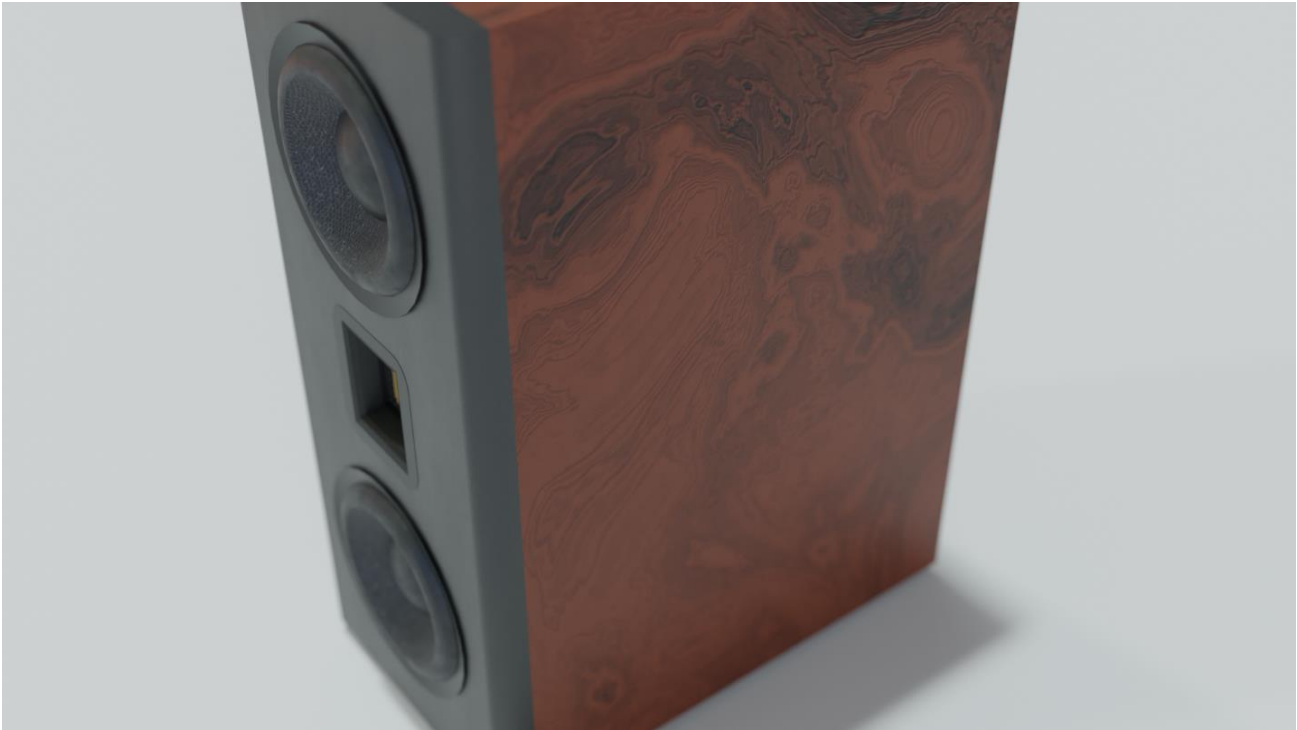

7.0 Construction

The first step in the building process was acquiring the materials. Luckily, I only needed a single sheet of plywood, so I had some flexibility in my wood choice. Typically, speakers are built using either MDF or high strength plywood. MDF is relatively cheap and offers a great deal of rigidity but is easily damaged. Additionally, working with MDF creates a large amount of small particulate, meaning wood dust will get absolutely everywhere, including in your lungs if not wearing a mask. Also, my chosen tweeters have a very open face, meaning it would be very easy for fine dust to come in and potentially damage my drivers. I want my speakers to be more durable for easier transportation as well as general longevity. For these reasons I ruled MDF out.

While plywood may be less rigid (depending on type), it offers many of the same benefits of cost and availability. The optimal choice in this category was Baltic birch, as it is rigid by nature and is produced with very high layer counts (11+ layers). Higher amounts of layers in plywood increase the rigidity of the panels. Unfortunately, due to the conflict in Ukraine obtaining Baltic birch was cost prohibitive.

After talking to my local hardware store, they only had two selections that would be meaningful in my design choice. The first was a standard piece of unfinished North American birch plywood with seven layers. The second choice was a five-layer birch ply with a very nice birch veneer. While this option was more expensive, I had the extra savings from fitting everything onto one sheet. Additionally, this would make achieving my desired look much easier. Losing the two layers meant the cabinet would be slightly less rigid, but the internal bracing will diminish this effect. This is the choice I went with.

Once the wood was brought to the shop, it was time to start building. The panels would be cut out of the sheet using a table saw. As the cuts were predetermined, it was a simple process of adjusting the cutting width and running the sheet through. However, the dimensions produced by Winspeakerz are very specific and don't necessarily translate into measurable distances of $1/16''$. So, it's best to round up the dimensions to the nearest $1/16''$ as it's easier to make a box smaller than larger after construction.

Due to the size of the sheet and the available working surface of the table saw, this was a two-person process, requiring someone to support the end of the sheet hanging off the table. While there was a guide surface to push the sheet along, it still took concentration and proper technique to achieve straight edges, especially with the larger dimensions. Having warps or curves in the edges of the panels would create gaps in the box, allowing leaks in sound and pressure, so it's very important to get the panels straight.

From there, I created the rabbet joints. This required changing the table saw blade to a rabbet blade, a form of blade designed to remove a greater width of material with a given depth. Next, the height of the blade is adjusted to half of the thickness of the panel, $3/8''$. Then, the cut width must be changed to support the width of each relative panel. Next, all I had to do was run the material along the saw while maintaining downward pressure to create a consistent cut. Like cutting the panels, the order of cuts should be done in a way to minimize the amount of adjustments between cuts, meaning I made the rabbet joints going by groups of like dimensioned panels. Here, it's good practice to run each panel through several times to create a consistent edge. Once this was completed, to make sure the cuts were done properly I put together the boxes in a test fit. Here, you can see how tightly the panels join:



The next step was to create the dado joints for the internal bracing. This was a very similar process to creating the rabbet joints, using the same wide blade. Here, the material is removed from the inside of the panels instead of the edges. Here is a test fit with the dado joints complete:



Next, I moved to cutting and inseting the holes for my drivers and ports. The circular holes for the woofers and ports were cut using a router with a radius guide. This is a simple attachment to a router with an array of available radii. A pin is placed at the given radius, and the router rotates around this pin. The first step was to create the inset for flush mounting the drivers, then cutting the remaining inner diameter. If the hole for the driver was cut first, there would be no material for the radius pin to sit in. The depth of the lip of the woofers was measured and the router depth was adjusted to this

measurement. Using this setup creates perfectly round holes as the router is locked into the specified radius. Before cutting, the panels must be held down to prevent movement. Then, all you must do is push the router around at a slow pace. With the inset done, I then moved to cutting the holes through the panels using the same technique. The port hole did not need to be inset as it is positioned at the back of the box. Here, diffraction and visual aesthetic were not as important. This was a time-saving decision. Additionally, a hole for the NL4 connection was made. Here, I used a saw bit on a drill press to create the perfect sized hole. Again, this did not need to be flush mounted as it exists on the rear of the boxes.

The tweeter insets were much more difficult to make because they feature a complex rounded square face. As before, the inset was done before the hole. To do this required the construction of a custom jig, made from scrap material from the shop. The scrap needed to be thick enough to act as a guide for the router, about an inch thick. To make this I simply squared the tweeter to the edge of the scrap piece, faced down, to the edge of the wood and traced its footprint. I then took this trace and cut the jig with a band saw. With the jig ready, I then attached it to the top of the panel. Before I did so I made sure I marked out the center line in both directions so I could squarely align the jig. With that, I was ready cut the inset. With the jig, this was as easy as creating the inset holes for the woofers. Although here, I needed to remove all material inside the edges. Once the inset was done, I simply cut out rectangular shapes for the tweeter to fit into with a jig saw. These didn't need to be pretty as they would be hidden behind the face of the tweeter; the tweeter just needed to fit through them.

With all the holes cut out and joints finished, it was finally time to glue the boxes together. Due to the size of the boxes, this was a two-person process. Each edge had a layer of Titebond III wood glue to seal the enclosure. More wood glue is better than less, as extra glue will help to fill in any gaps. When the panels were all joined together, I then clamped them down as much as possible. As there was minor warping in some of the panels, the clamps would help straighten them out and make them more flush with the rest of the box, as well as further reducing the potential for gaps. Below are images featuring the clamps as well as an internal view of the bracing:



While the glue dried, I took the time to cut my ports down to proper length. The ports that I ordered came with a tube length of about 18" so that it could be cut down to a large variety of port lengths. This tube sits in between the inner and outer flairs and is attached with cuffs extending over each piece. The final length of the port must include the length of the flairs at each end, so the tube length must be altered accordingly. Once the tubes were cut down to size, I used Gorilla glue to seal them in place. Looking back, this was a premature move as it's very likely the port length would need to be changed in the tuning process.

When the glue finished drying, it was time to begin sanding and finishing the surface of the boxes. Sanding was done with a palm sander and high grit sandpaper. This removes some of the extra glue that seeped out during clamping, as well as smoothing out the overall finish of the box. After sanding, I moved onto rounding the front baffle edges. The rounding was done with a router table and was very simple. All I had to do was run the edges of the front baffle along the router. This produced a very clean and even rounded edge around the front of both of my boxes. The rounded edge also aids in edge diffraction, where the sound waves are sheered as they move from the baffle into free space.

The next step was to add some insulation to the inside of each box for some extra dampening of mid to high frequencies. For this I used a recycled denim material with a consistency similar to a light wool. This was stapled to the inside of the boxes with a small pneumatic staple gun in a layer about 1/2" thick. Every surface was covered except the front baffle where the drivers are installed.

From there it was time to wire and install the drivers. Before wiring, I drilled small pilot holes aligning with the screw positions of the drivers. This creates a channel to guide the screw when it is drilled in, keeping it straight and preventing separation of wood grains.

The two woofers are wired in a parallel circuit. To do this, I simply split the connection coming off the NL4 connector in two using a wire nut to connect the three wires together. The woofers are wired in parallel to produce a 4-ohm load that is compatible with a majority amplifiers. The tweeters are directly wired into the NL4 connection, with the exception of the 20mf capacitor used as protection for voltage spikes on the tweeter. This produced an 8-ohm load. The end of each wire was terminated with quick disconnect connectors which easily slide onto both the NL4 connector and the connection tabs at the back of each driver.

Once the wiring was complete and insulation installed, it was finally time to install the drivers. As the pilot holes were already completed, this was as simple as screwing them in. The woofer drivers mounted perfectly flush with the front of the boxes, partially due to the padding behind the front lip. However, the tweeters did not mount as nicely.

In cutting the jig, it was clear that I may have been a bit overzealous and made some of the corners a bit too wide. This resulted in a gap between the edge of the tweeter and the inset. To fix this, I mixed sawdust with a clear glue to create a form of wood filler to try and fill in the gaps. Before applying this, I masked off the front of the tweeter. Then I applied the filler. After setting, I was able to remove the masking and see how well it had worked. Unfortunately, some of the filler came out when I removed the tape. This looks a little rough, but it should do a good job of providing a smooth surface around 90% of each tweeter.

At this point, the construction process was complete:



8.0 Testing

Testing was done using Smaart V8 and Fuzzmeasure, two powerful acoustic measurement programs the sound program has loaded onto available computers for students to use freely. Smaart was used for SPL calibration, phase alignment, and frequency response. This ensures measurements are done at the proper SPL for harmonic distortion measurements. Fuzzmeasure was used to acquire full measurement data and provides clean and easy to use plots. In testing, I needed to acquire:

- SPL at 1m for each woofer/tweeter.
- Frequency response for each driver and the full system.
- Integrated frequency response showing the individual response of each driver on a single plot.
- Harmonic distortion for each driver and the full system.
- Horizontal and vertical off-axis response at 30 and 60 degrees.
- Step response of each driver.
- Integrated step response featuring both drivers on one plot.
- And finally impulse response of each driver and the overall system.

The first step in the measurement process is calibrating the microphone and SPL. This was done with the use of a specialized microphone calibration tool that emits a specific SPL. This tool is placed on the end of the microphone, encompassing the diaphragm. The microphone preamp is adjusted to where the readout in Smaart matches the SPL produced by the calibration tool. If the calibration tool is set to produce 94dB, the reading in Smaart should also display 94dB. This calibration process is done at the start of each testing session, or when any of the microphone parameters are altered.

Next, the microphone is placed one meter away from the front of the speaker, directed towards the speaker. Before producing sound, all crossover and EQ should be disabled in the DSP. The woofers are first up in the testing process. As I'm using an MTM design, the measurement should be acquired directly between each woofer to prevent destructive interference between the two. Also, in this test the tweeter should be disabled. The woofers are tested with a full range pink noise through Smaart. In Smaart, the pink noise is enabled. Then, the woofer amplifiers are adjusted to produce 83dB. If the microphone level was adjusted instead, the calibration would be meaningless. With the pink noise going, the frequency response of the woofer is captured. Next, the data is acquired by Fuzzmeasure using a sine wave sweep, averaged over three iterations. The level of these sweeps is reduced to -10dB to match the output of Smaart. Here's what Fuzzmeasure captured for the woofers at 1m.

Frequency Response (1/24 Octave Smoothing)

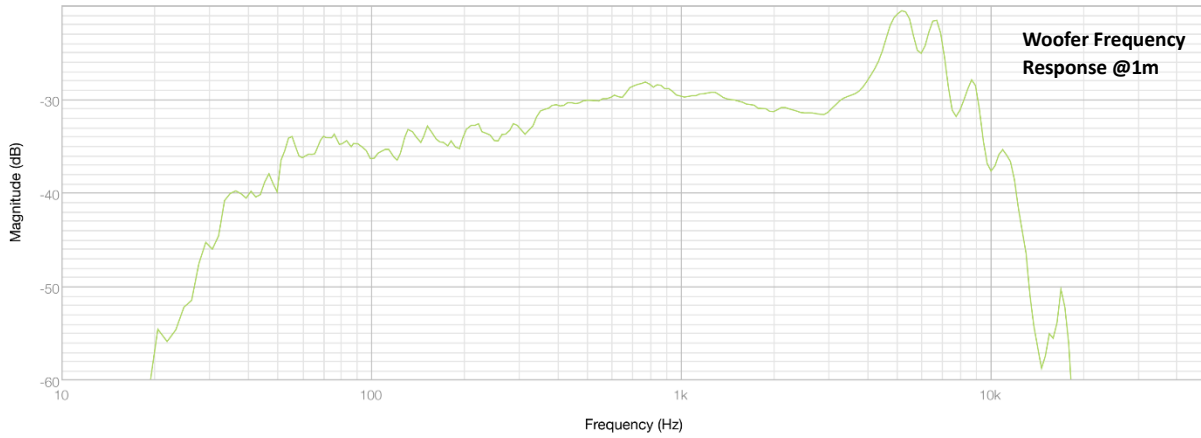

Sound Pressure Level (1/24 Octave Smoothing)

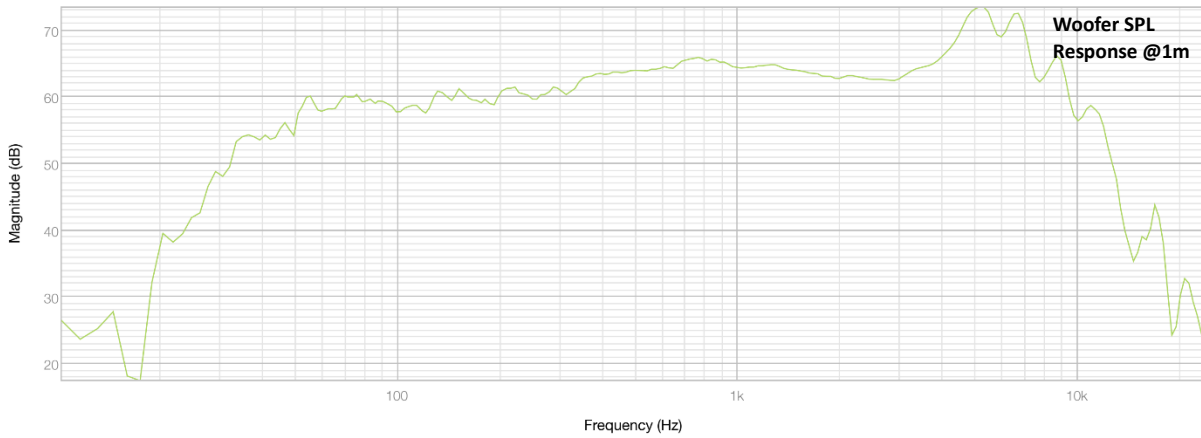

Harmonic Distortion Percentage (1/24 Octave Smoothing)

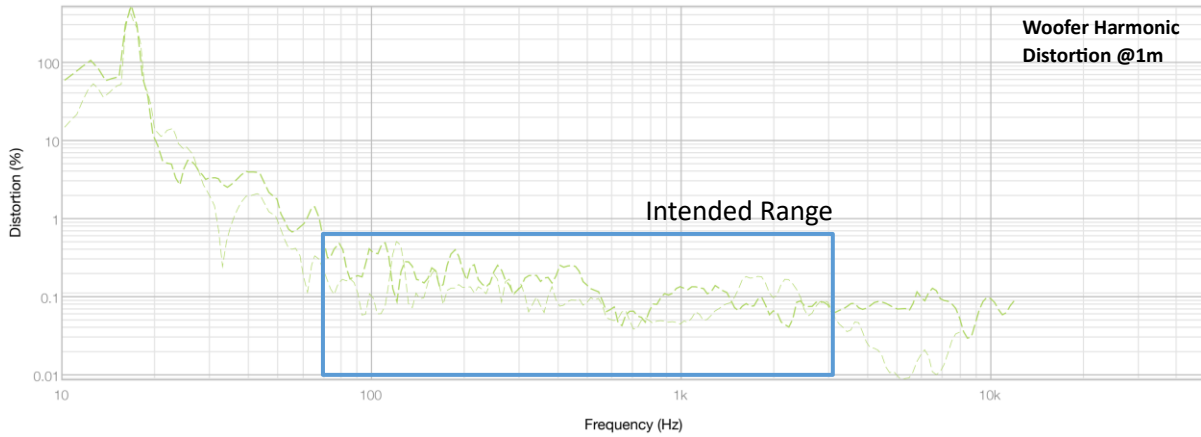

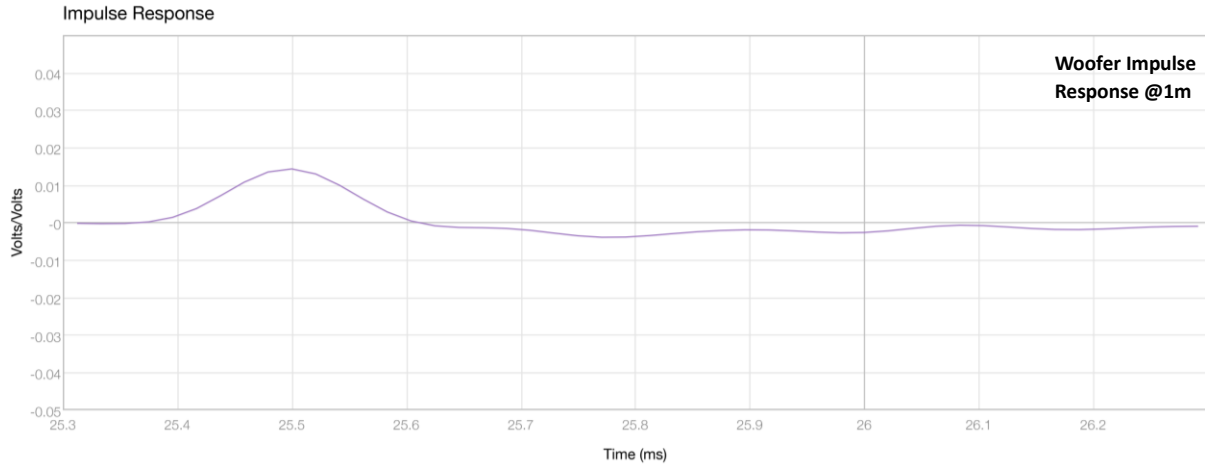

Next, the tweeter is measured in the same way. As the tweeter is centered between the two woofers the mic position does not need to be altered. Here's what Fuzzmeasure captured from the tweeters at one meter:

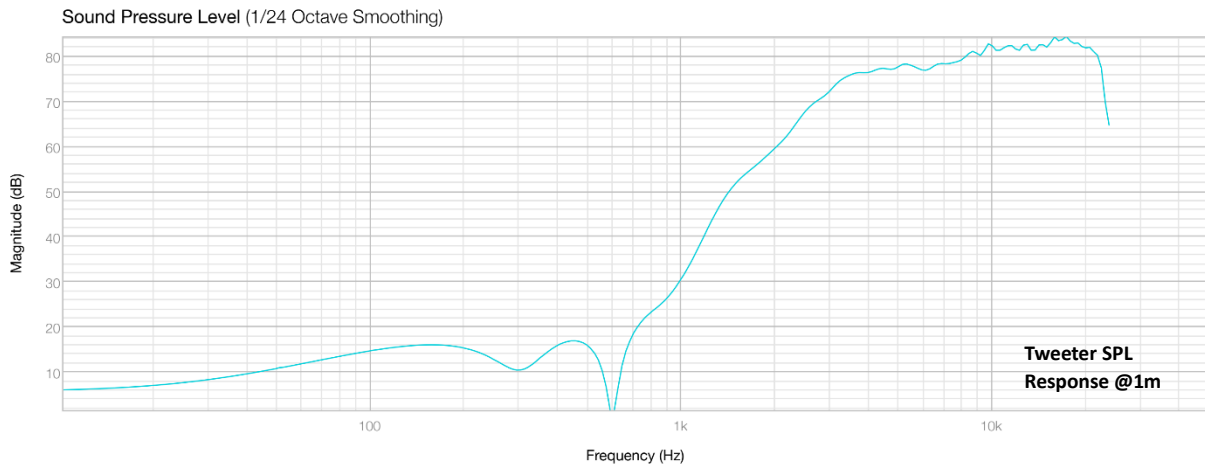
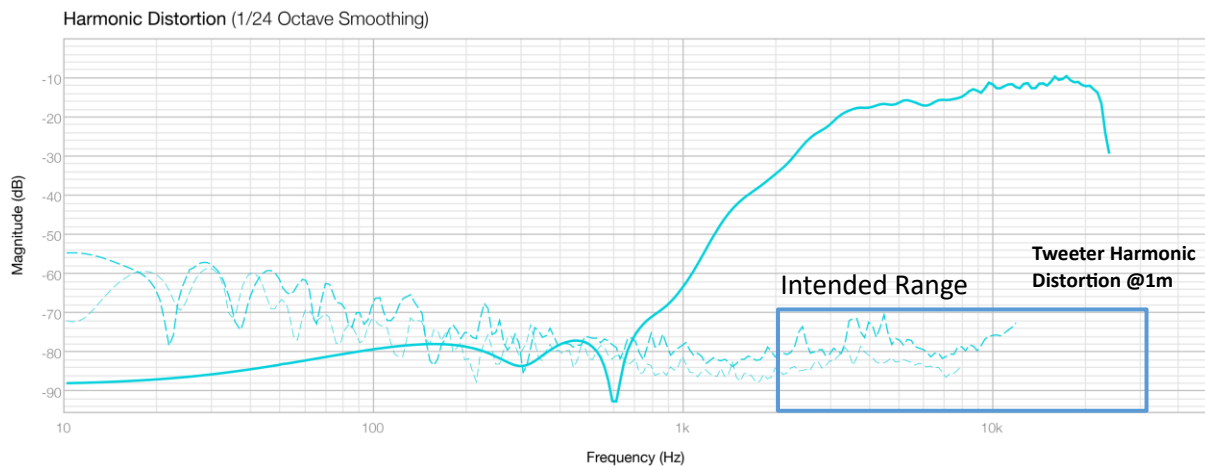

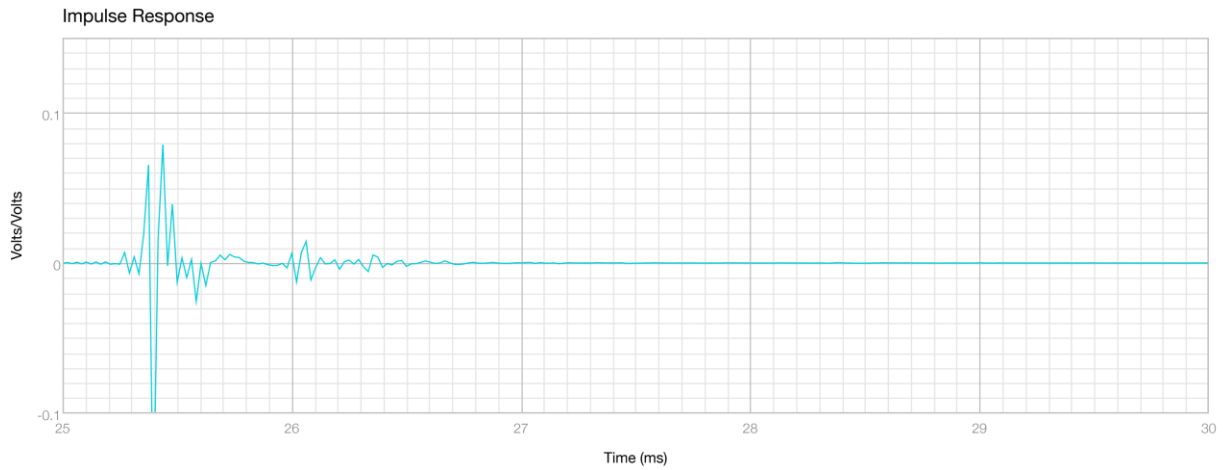

Unfortunately, it appears that the frequency response plot of the tweeter was exported as a duplicate of the harmonic distortion plot. However, the SPL graph shows much of the same data, with an alternate vertical axis scale.

Next, I moved onto testing the drivers at a very close distance, about one inch. This follows the same process as earlier, however for the woofer measurements the microphone must be placed in front of the single driver instead of positioned between the top and bottom drivers. This is what Fuzzmeasure captured for the 1" woofer measurements:

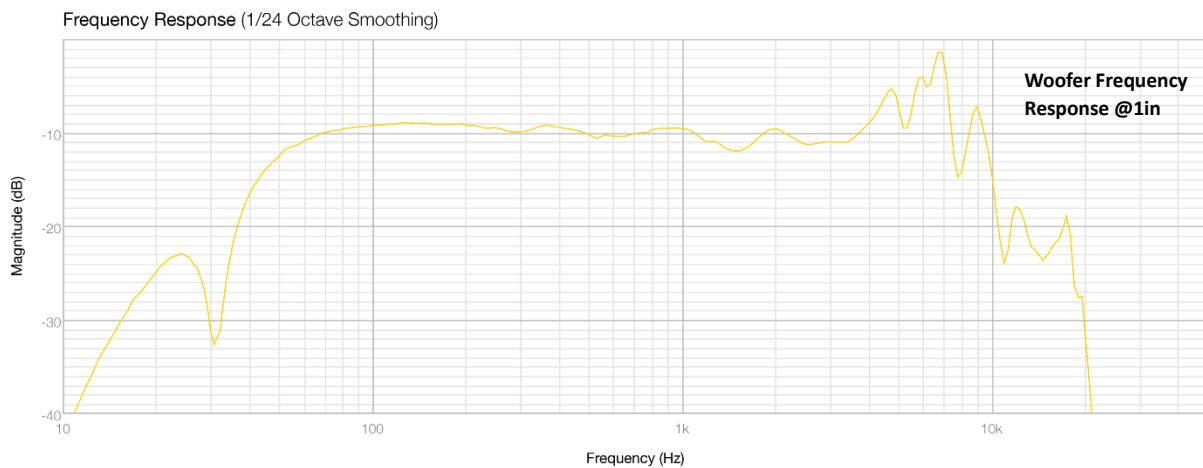

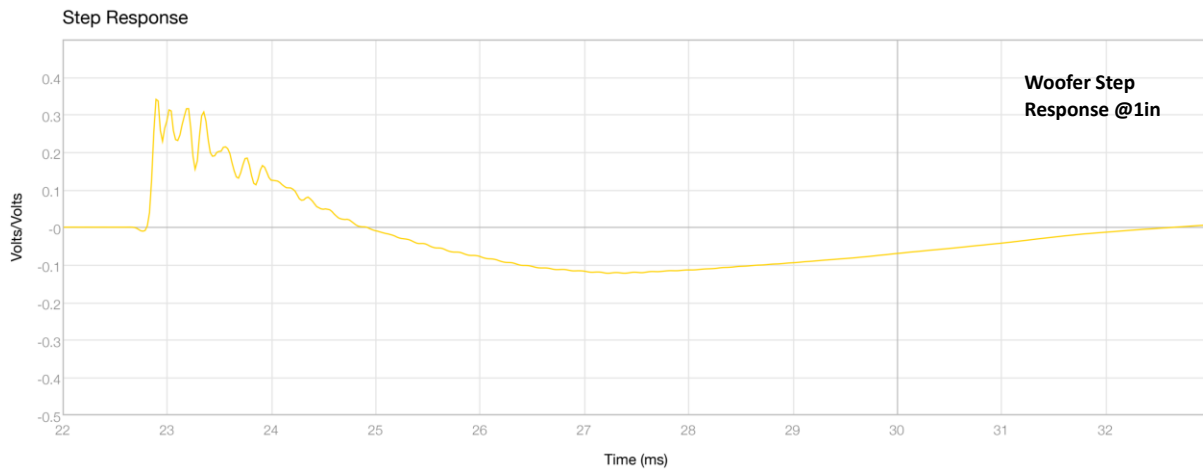
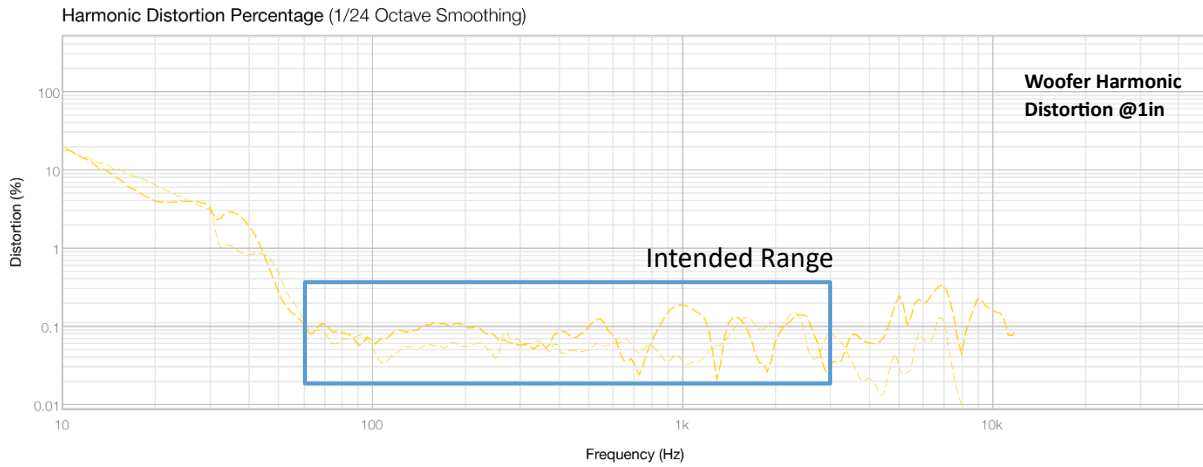

Next, I did the same for the tweeters, being sure to keep the same distance as the woofers:

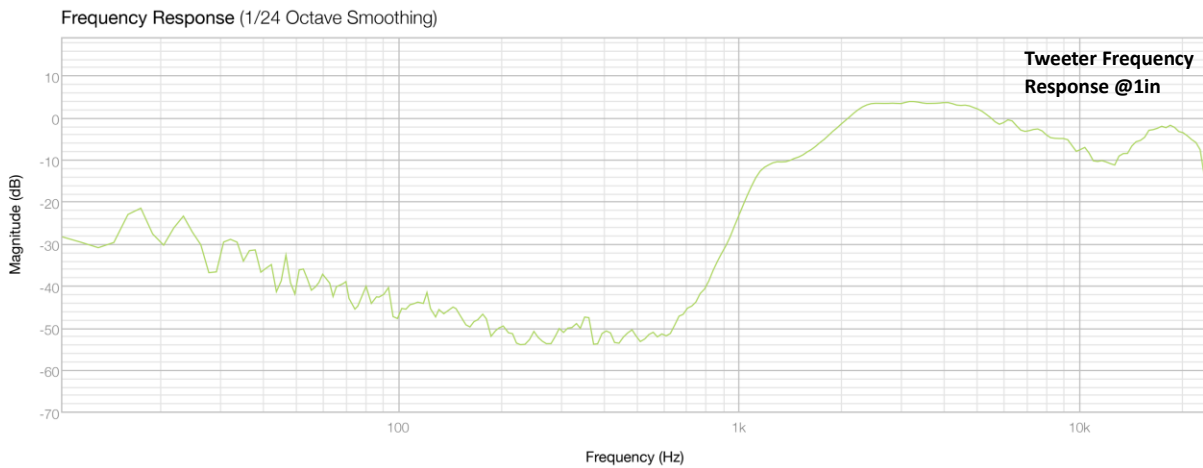

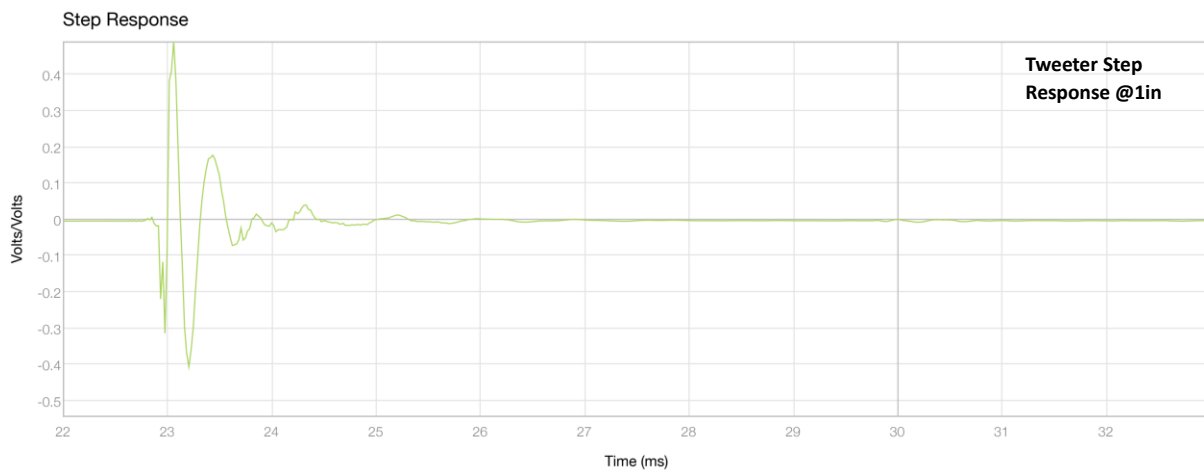
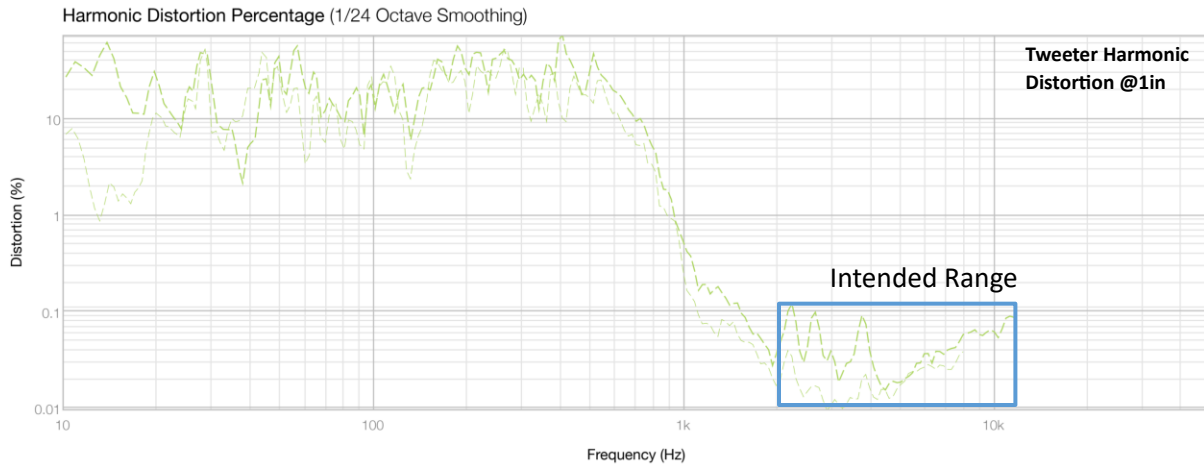

Finally, I combined the close miced frequency responses and one-meter step responses of the tweeters and woofers:

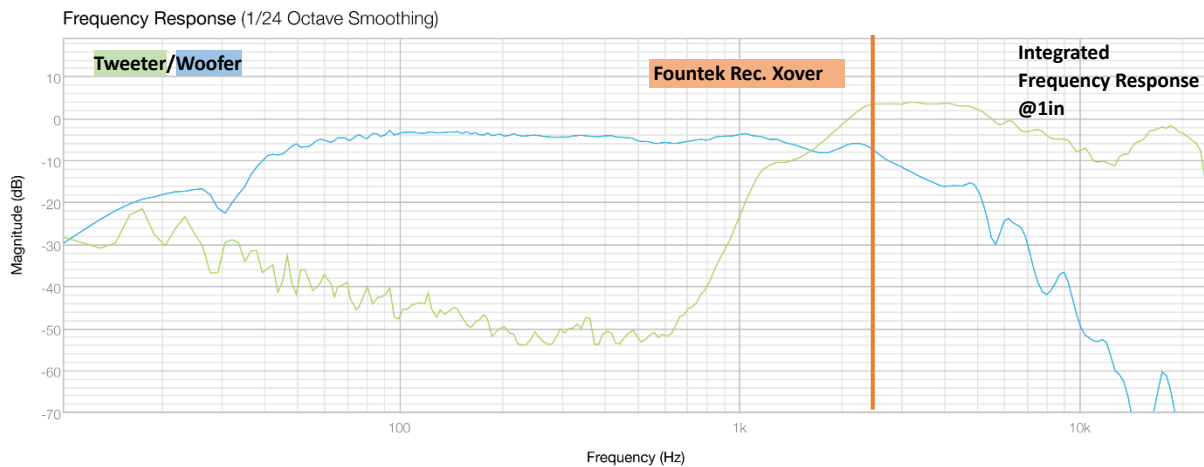

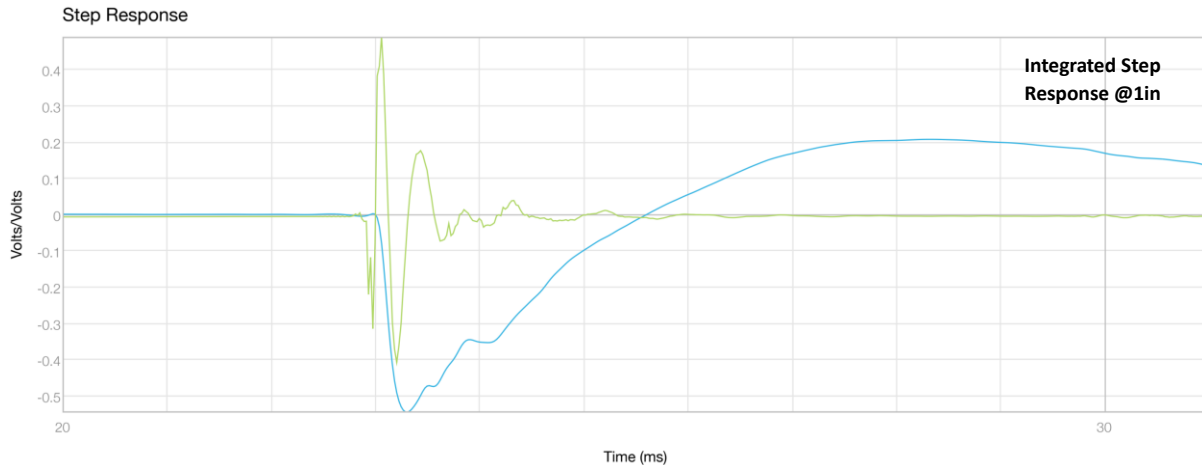

In looking at these data, we can see that the woofer offers the same linearity as described by the manufacturer, with an impressively low harmonic distortion below with an average around 0.1%. However, this linearity begins to fall off at around 200Hz due to baffle step at one meter. Additionally, we can see where the port begins to extend the low end response at around 25Hz in the close miced plot. However, there is a significant dip between this and the natural response of the woofers. Contrasted with the one-meter measurement, the reinforcement is diminished resulting in a more natural slope. With this, I could either trim the port, bringing up the frequency to increase the power handling of the woofers, countering the baffle step, or I could leave it as is and enjoy the low frequency extension. For time and personal preference, I decided to do the latter.

In looking at the close measured frequency response of the tweeter, there is a significant deviation from the manufacturer provided data. However, when looking at the one-meter measurement, the data lines up perfectly. This leads me to believe that the manufacturer tested this driver at one meter and not close miced. Conversely, the woofer matches perfectly at the close measurement, and deviates in the one-meter measurement. This signifies the importance of checking measurement data context from manufacturers and demonstrates their general lack of transparency as neither measurement included the distance the data was acquired at.

However, looking at the frequency response of the tweeter it has a gradual upward slope past 2kHz with little deviation. The harmonic distortion is also very good, lying below 0.1% across the usable spectrum.

Moving to the integrated frequency response plot we can see how the drivers will interact with each other, helping me choose a crossover point. As you can see, these drivers have a great deal of overlap meaning the choice in crossover point is very flexible. If the response of the tweeter was adjusted to meet the level of the woofer, they would naturally cross over at around 2.5kHz, precisely the manufacturer recommended crossover point for the tweeter. To start, I chose a 3kHz crossover point so I could have options in moving it up or down in frequency.

The integrated step response looks perfect. In green we can see the tweeter carrying the initial response, perfectly handing it off to the woofer in the downward transient. This means that the drivers are perfectly phase aligned with no delay adjustment! This is due to the tweeter being horn loaded,

effectively sitting on the same axis as the dust cap of the woofer. When signal is emitted, the tweeter and woofer essentially play simultaneously.

Now that I have identified the crossover point, I can go into the DSP and apply that to the drivers. The Fountek recommends a 3rd order curve for the crossover, translating to 18dB/octave. This will be applied to the low pass on the woofers and the high pass on the tweeters. Additionally, as identified by the integrated step response plot, no delays need to be applied to either the woofers or tweeter. To measure the full system, the microphone was placed directly in front of the tweeter at one meter.

After the crossover was applied, I measured the overall frequency response of the system:

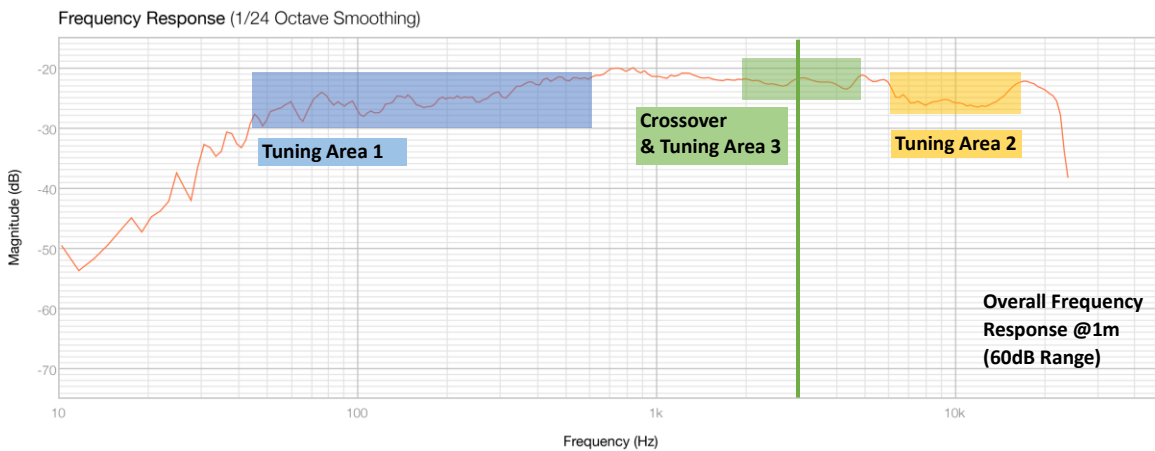
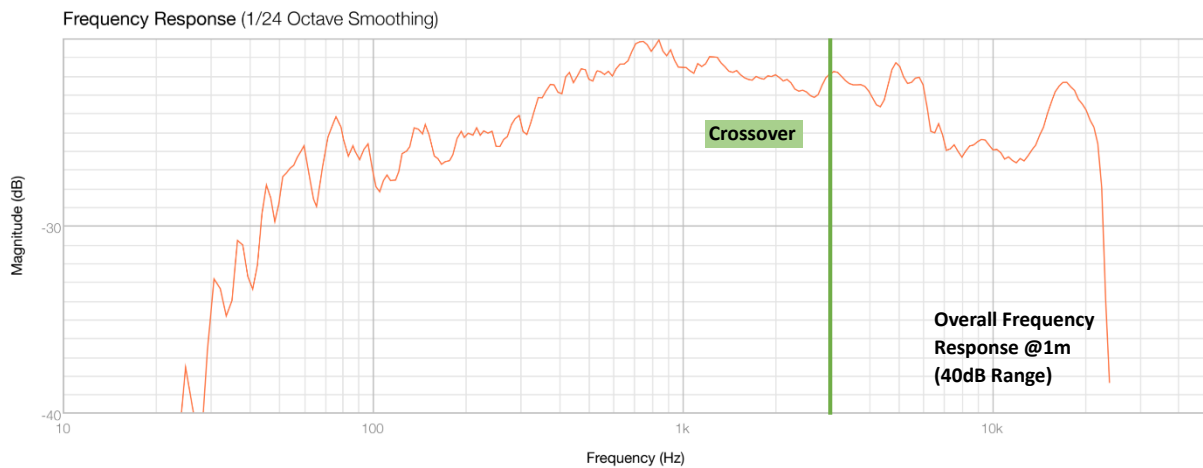

Looking at the crossover point of 3kHz, the frequency response maintains a very smooth transition, causing little significant variation. I then tested the vertical and horizontal off axis response of the full system. **Note: The vertical test was done at a later date and erroneously includes the subwoofer as part of the measurement, crossed over at 80Hz, and an early EQ setting. The inclusion of the subwoofer is of little consequence as the prominent features of this plot appear well above the**

crossover frequency. Additionally, this measurement was taken much closer to the floor resulting in slightly greater deviation in the 100-1kHz range.

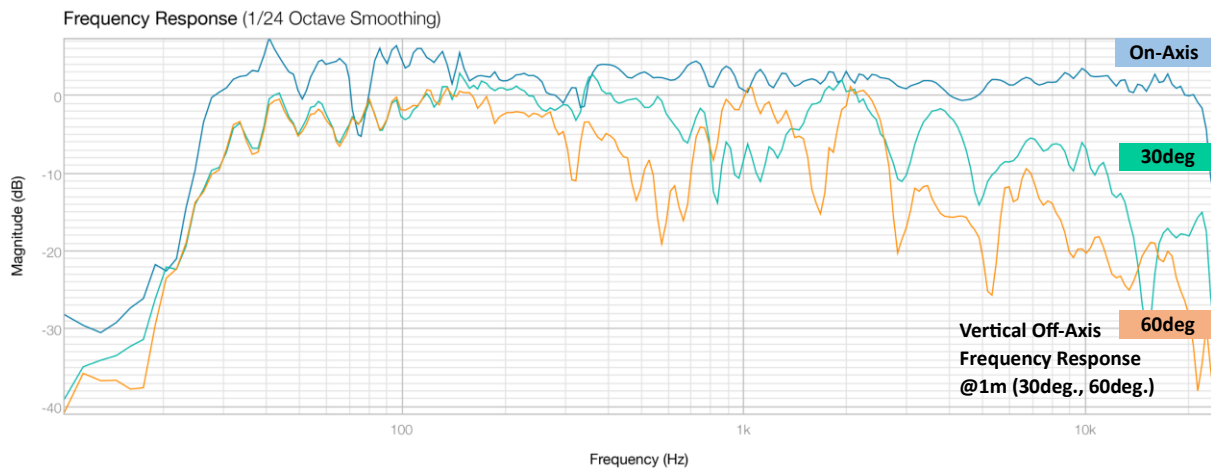
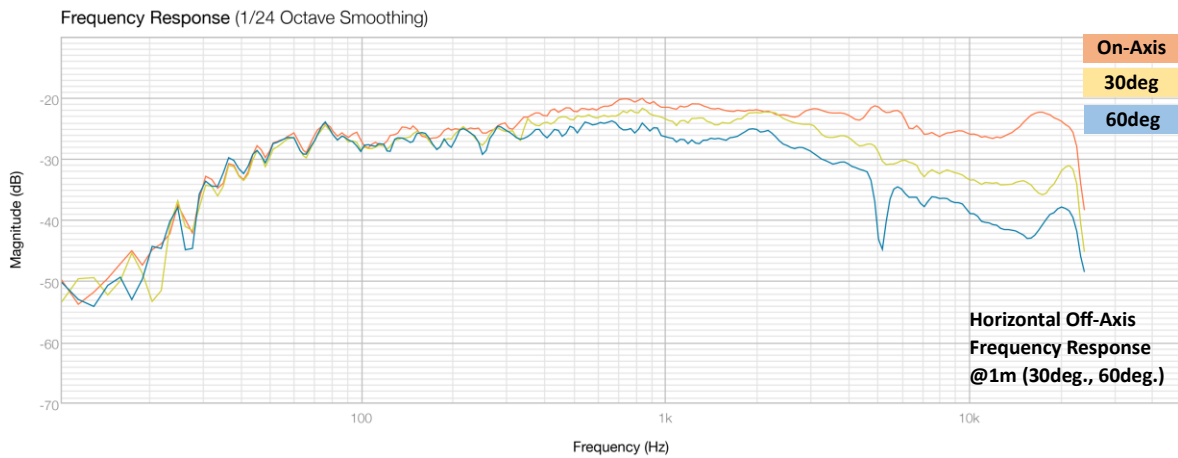

In the vertical off-axis frequency response, we can see the destructive interference of the MTM layout in the vertical direction. This is what contributes to its vertical directionality and reduces the total amount of energy distributed vertically in the room. We can see that large reduction in SPL starting at around 300Hz. Additionally, the changing phase relationship between the woofers as the angle is changed results in very different off axis responses at 30 and 60 degrees. Conversely, we can see the responses realign past the crossover point at 3kHz where the single tweeter takes over. Again, there is a large deviation in SPL between the on and off axis responses, further contributing to vertical directionality.

In the horizontal plain, the SPL reduction is less pronounced and offers a greater symmetry between the on and off-axis responses. We can see the directionality of the horn beginning at 3kHz where the signal begins to deviate. This symmetry allows for a much smoother transition between on and off-axis listening positions and prevents comb filtering, distorting the signal at more extreme angles. This will contribute to an widened horizontal listening axis.

9.0 Tuning

At this point I'm very pleased with the crossover and will move onto tuning. Fortunately, the tuning process was very quick as I achieved a great result with only a few edits. In Smaart, I activated the pink noise and began to add EQ to problem areas in the frequency response. I kept the pink noise playing continuously and checked the frequency response after each edit.

The first area I tackled was the baffle step of the woofers. This was fixed with a simple +6dB low shelf up to 250Hz. Next, I added a +4dB bump at 2.5kHz with a Q of 2.5. I then tried to fix the dip in the tweeter past 6kHz. This was fixed with a +2.3dB boost at 6.5kHz with a Q of 5.8. Then I added a -4.7dB cut at 5kHz with a Q of 5.8. Finally, I added a -3dB high shelf at 16kHz to smooth out that hump. These are the results of the tuning:

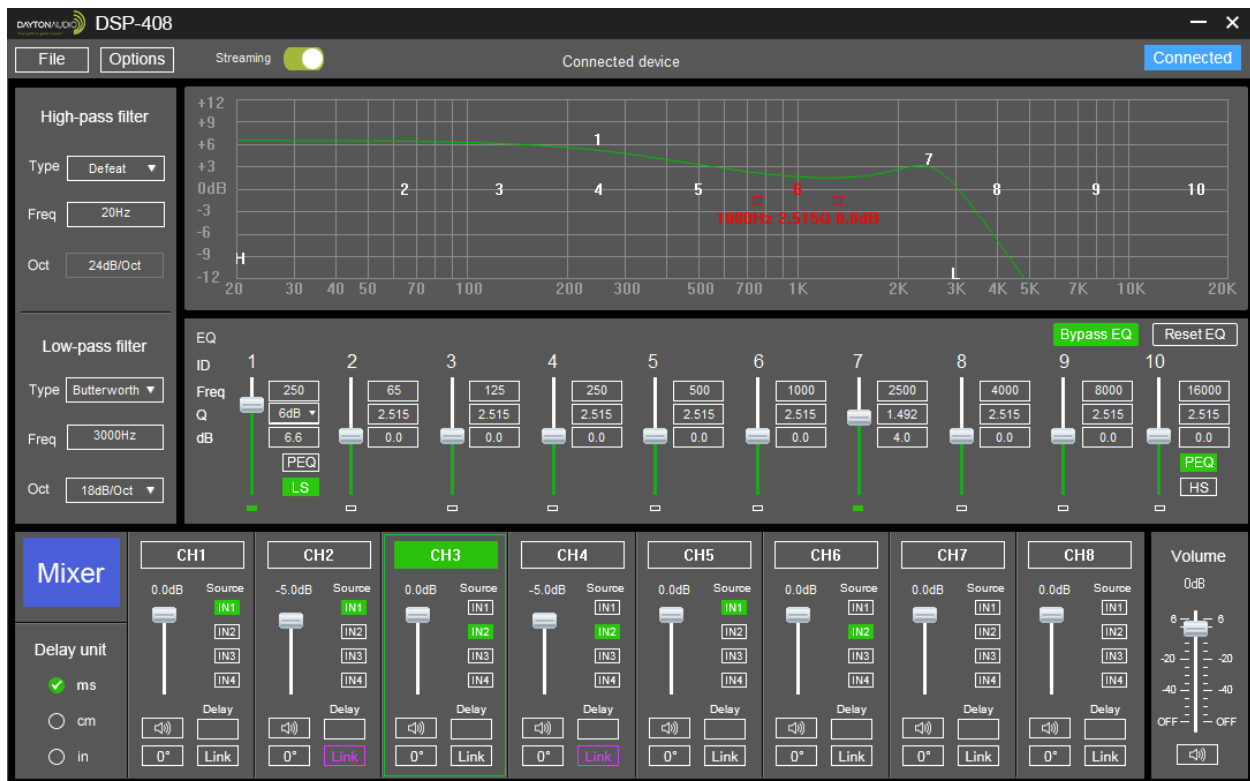

Woofer EQ

DAYTON AUDIO DSP-408

File Options Streaming Connected device Connected

High-pass filter
 Type: Butterworth
 Freq: 3000Hz
 Oct: 18dB/Oct

Low-pass filter
 Type: Deafat
 Freq: 20000Hz
 Oct: 24dB/Oct

EQ
 EQ 1 2 3 4 5 6 7 8 9 10 Bypass EQ Reset EQ
 Freq: 31, 65, 125, 250, 500, 1000, 2000, 5000, 6500, 16000
 Q: 2.515, 2.515, 2.515, 2.515, 2.515, 2.515, 2.515, 5.764, 1.983, 12dB
 dB: 0.0, 0.0, 0.0, 0.0, 0.0, 0.0, 0.0, -4.7, 2.3, -3.0
 PEQ, LS, HS

Mixer
 Delay unit: ms, cm, in
 CH1: 0.0dB, Source IN1, Delay 0°, Link
 CH2: -5.0dB, Source IN1, Delay 0°, Link
 CH3: 0.0dB, Source IN1, Delay 0°, Link
 CH4: -5.0dB, Source IN2, Delay 0°, Link
 CH5: 0.0dB, Source IN1, Delay 0°, Link
 CH6: 0.0dB, Source IN2, Delay 0°, Link
 CH7: 0.0dB, Source IN1, Delay 0°, Link
 CH8: 0.0dB, Source IN1, Delay 0°, Link
 Volume: 0dB, -20, -40, OFF

Tweeter EQ

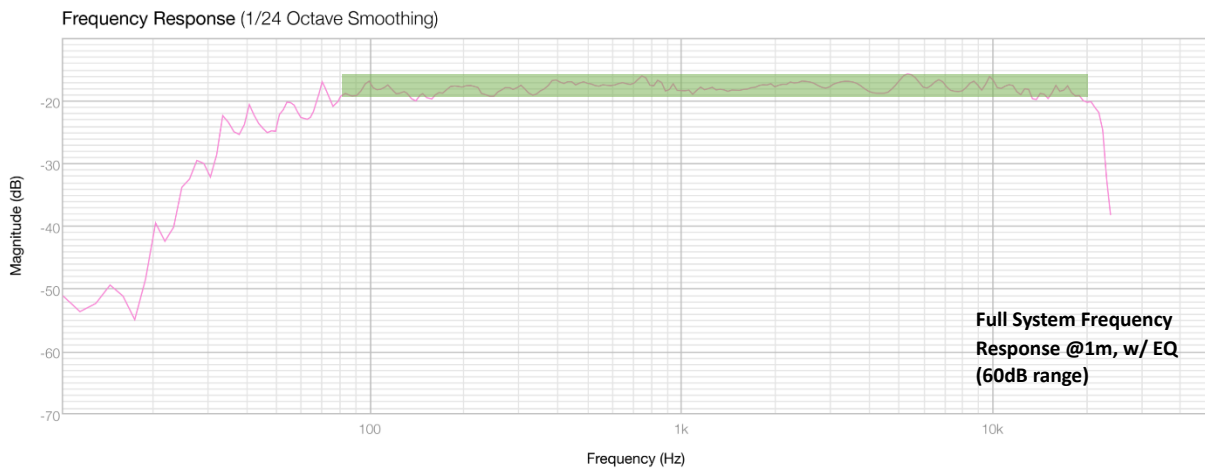

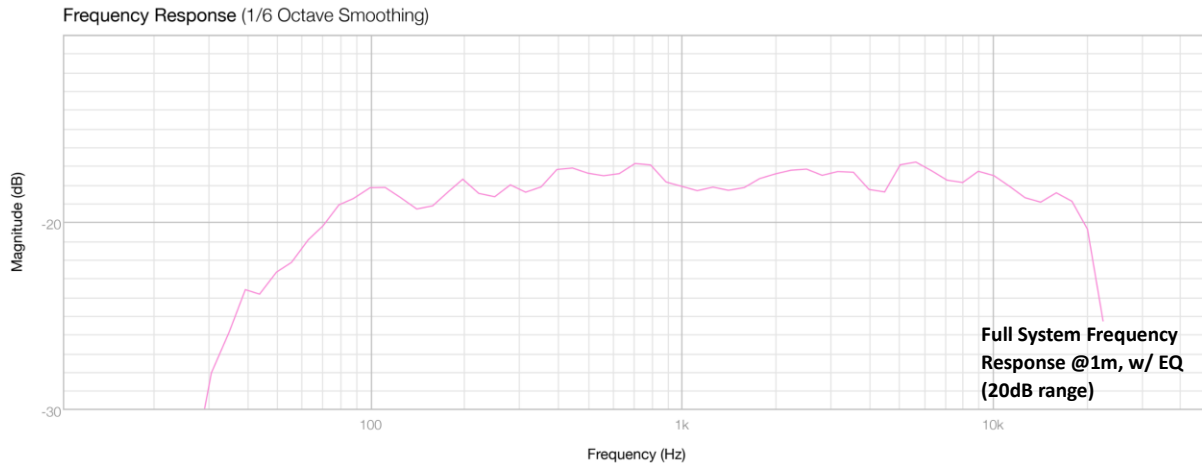

Wow! From these we can see a very flat response from 100Hz up to 20kHz of +/- 2dB! This means there's only a maximum 4dB difference between the loudest and softest frequency in the given range! For mixing monitors, this is exactly what we want to see. For time, this is the finalized tuning, but there could be a slight boost to the woofer low shelf to bring up the response around 150Hz. If this was done, it's possible the frequency response could be brought down to +/- 1.5dB from 100Hz to 20kHz. This could be achieved either through EQ or shortening the port length as described earlier. However, I'm very pleased with +/- 2 dB and will leave it here until time allows for further testing.

Final Listening

With the tuning complete, it was time to throw on some tunes and give them a listen. Before doing so, I hooked up the subwoofer as part of the system and set the crossover point to 80Hz. I then listened to a variety of music and adjusted the level by ear. As this was done in my bedroom, acoustic measurements weren't able to be acquired, hence adjusting by ear.

To start, I used a playlist created by Josh Loar (an ex-sound professor at Michigan Technological University), which features a variety of specialized songs and their relative details for critical listening. This playlist includes songs with heavy bass, broad stereo effects, oversaturated mids, depth and width of soundstage, and just well recorded songs in general. Each song comes with a description of what to listen for, and where cheaper speakers may fail in producing a clean response.

JL speaker test list:

“Get Lucky” by Daft Punk

Listening for overall spectral balance, tonal accuracy. Vocal clarity for lead, backgrounds, and vocoder. Crisp transient response/low resonance.

“Teil II” by Kjartan Sveinsson

Dynamic range subtlety and noise floor. Depth of field. Width of stage. Full-range signal without frequency/harmonic distortion (particularly starting around 6:20 of the piece).

“The Healer” by Erykah Badu

Subbass extension and resolution. Depth of field (particularly on vocal verb). Overall frequency range from subbass to hissing noise at HF extension.

“Wow” by Beck

Subbass extension and resolution. Tonal midbass without overresonance. L/R separation.

“Aberinkula” by The Mars Volta

Time/transient crispness. Midrange clarity when oversaturated. Heat handling of compressed material. Treble clarity without unnecessary harshness.

“The Earth Died Screaming” by Tom Waits

Handling of Waits’ distorted vocal. L/R separation. Depth. Distinction of tones within the midrange (bass from plunked percussion).

“oh baby” by LCD Soundsystem

Perceived size of space (reverb). Handling of slightly distorted bass synth. Separation of kick from bass synth.

“Take Five” by Dave Brubeck

Width of soundstage. Clarity of breathy tonality in lead reed part. Depth. Audibility of potential edit point(s) (e.g. 1:52 ish in the song). Tom-tom tone (too resonant, not resonant enough? Sounds like a basketball or like tuned toms?).

“Money” by Pink Floyd

L/R separation. Tonal separation between instruments. Bass vs kick clarity. Snare midrange thump (vs crack or mush). Tom-tom deadness. Steady decay of fade out.

“Chartnok” by Mouse on Mars

Buzzing tones, overloaded distorted tones. Quick and crisp transient response. Stereo separation. Clarity of tones when faced with multiple overlapping tones and textures playing simultaneously.

After listening through this playlist, it’s safe to say these speakers check all the boxes: The low mid detail is great, allowing for clear separation of kick and bass in muddy tracks, as well as a smooth bass response with no clear resonant notes. There is almost no coloration of the sound as we can see from the very flat frequency response, except for when the subwoofer is not properly adjusted to the listening environment. The tweeters are simply sweet. They offer an impressive width and depth of soundstage, sometimes appearing as if sound emanates from behind the listener if positioned perfectly between the speakers. Finally, the detail and transparency the ribbon tweeters offer is unparalleled by

dome tweeters. While they might not have that transient snap of dome tweeters, the transparency is a fair tradeoff. The phantom center between these speakers is also rock solid, allowing for a clean stereo image with greater variation in listener position along the horizontal axis. Due to the vertical directionality, they offer additional benefits when placed in an untreated room. Because the sound is disrupted or directed, there are significantly fewer surface reflections from my desk, ceiling, and floor. This improves the imaging of the speakers as well as a smoother frequency response at the listening position.

10.0 What I Learned

One of the most important aspects of approaching a large project like this is time management. That starts with being prepared and doing your research. If the design is done incorrectly or with little regard for detail, the work later down the line will be much greater than you anticipate. This could bring you back to square one in your design, potentially setting you back days or weeks.

Next, be methodical in your approach. Don't begin by simulating the box. Start with the thousand-foot view of the project, determine your broad needs, and narrow it down from there. This ensures the design stays relevant to use. This extends to the testing phase. Know what you need and how to obtain it before you begin testing. This allows for more time actually analyzing the data and tuning your speakers rather than running around trying to get your data correctly. Having a list and detailed notes improves this process greatly.

During the build process, give yourself 3X the amount of time you think you need. In speaker building, being precise should be one of the main objectives. This takes time, especially if you're not prepared before entering the shop. This also gives you time to learn the tools and develop proper techniques to achieve the level of quality you're after.

Finally, ask questions. Go online to speaker forums or do some personal research to answer any questions you may have. As an engineering process, designing speakers can't be done through intuition or blind faith. You must know what affects the outcome before you change something. This is especially true in box design, as the dimensions of the box cannot be altered once it's built.

To conclude this paper, I'd like to extend my thanks and gratitude to Professor Christopher Plummer of Michigan Technological University. He was our greatest aid in the design and tuning process of these speakers. Even though he was extremely busy, he always took the time to give thoughtful answers and help to any student who needed it. Additionally, I'd like to thank Matthew Moore, the MTU Scene Shop supervisor. He taught us how to use the tools of the shop and aided greatly in the construction of these cabinets. With his help, I was able to achieve a beautiful result. He always has a friendly disposition and was always willing to help as much as possible.

11.0 Final Cost

Name	Use	Number	Cost (Each)	Cost (Total)
Fountek Neo CD3.5H	Tweeter	2	\$106.50	\$213.00
CSS LDW7	Woofers	4	\$161.00	\$644.00
Birch Veneer 4'x8' Plywood	Wood	1	\$113.00	\$113.00
Precision Port 3" Flared Port	Port	2	\$24.99	\$49.98
Neutrik NL4MPRXX	NL4	2	\$4.99	\$9.98
Fosi Audio V3 Stereo Amp (300Wx2)	Amp	2	\$89.99	\$152.62
Dayton Audio 4x8 DSP	DSP	1		\$164.98
			Total Cost:	\$1,347.56 + Shipping

Final Images



12.0 Bibliography

- “8361A.” Go to Genelec.com. Accessed December 17, 2023. <https://www.genelec.com/8361a#section-technical-specifications>.
- Colloms, Martin. *High performance loudspeakers*. 7th ed. London: Pentech Press, 1985.
- Dickason, Vance, and Shannon Becker. *Loudspeaker Design Cookbook*. 7th ed. Peterborough, NH: KCK Media Corp., 2023.
- E. “Focal Twin6 Be Studio Monitor Review.” Erin’s Audio Corner. Accessed December 17, 2023. https://www.erinsaudiocorner.com/loudspeakers/focal_twin6be/.
- Katz, Bob. “Level Practices (Part 2).” Digidio.com, April 9, 2017. <https://www.digido.com/portfolio-item/level-practices-part-2/>.
- “KH 310 A L G.” KH 310 A - Three Way Nearfield Monitor. Accessed December 17, 2023. <https://www.neumann.com/en-en/products/monitors/kh-310-a/>.
- Newell, Philip Richard, and K. R. Holland. *Loudspeakers: For music recording and Reproduction*. 2nd ed. New York: Routledge, Taylor & Francis Group, 2019.
- Nikolic, Julijan. “Loudness Standards - Full Comparison Table (Music, Film, Podcast).” Youlean, December 13, 2021. <https://youlean.co/loudness-standards-full-comparison-table/>.
- PresentDayProduction. *Once You’ve Heard It You Can’t Un-hear it! | ATC SCM45A Studio Monitors*. YouTube. YouTube, 2021. <https://www.youtube.com/watch?v=P7yI5cm9pTo>.
- Robert Lang installs ADAM Audio S5H’s*. YouTube. YouTube, 2018. <https://www.youtube.com/watch?v=1onDe-rXtgQ>.
- “S5H Active Studio Monitor (Main Monitor).” ADAM Audio, June 7, 2023. <https://www.adam-audio.com/en/s-series/s5h/>.
- “SCM45A Pro.” SCM45A Pro | ATC Loudspeakers. Accessed December 17, 2023. <https://atc.audio/professional/loudspeakers/scm45a-pro/>.
- Toole, Floyd E. *Sound reproduction: The acoustics and psychoacoustics of loudspeakers and rooms*. 3rd ed. New York, NY: Routledge, 2018.