

## Samba MT Pair – PartsExpress

Medium Size Pair of Studio Monitors for Mixing Use in a Bedroom Studio Environment

*Constructed by: Bradley Summers*



## Table of Contents

1 Functional Description .....	3
1.1 Foreword.....	3
1.2 Pre-selection .....	3
1.2 Post-selection.....	3
2 Reference systems.....	4
2.1 Overview/Table.....	4
2.2 Specific Examples .....	5
3 Technical Specifications.....	8
3.1 Physical Design/Cabinets .....	8
3.2 SPL Requirements .....	9
3.3 Drivers .....	9
3.4 Amplifiers .....	11
3.4 Frequency Response .....	12
4 Bibliography .....	13

# 1 Functional Description

## 1.1 Foreword

The following section will reflect my initial thoughts on what I wanted out of this project before I settled on the Samba kit. The section after will go more into detail about why I chose the kit and the assembly process.

## 1.2 Pre-selection

This pair of loudspeakers will be primarily used for mixing incomplete tracks in a personal studio environment. Size will be a large factor in this design, as the space provided for these speakers is not likely to be very accommodating. As such, the overall goal with this project is to create a set of speakers that are budget friendly and small enough to fit in a small apartment bedroom, while not making dramatic sacrifices on sound fidelity that would essentially render them useless for mixing.

The space for the speakers will not require an excessive amount of SPL, since they will likely be placed at a desk or somewhere that is reasonably close to the listener. They don't need to be the loudest speakers on the market, but their frequency range should extend low enough to make them good enough for mixing.

One of the main goals for this system is to listen backwards to get the best idea of the original sound of a track possible. To accomplish this, these speakers need to be low distortion, and capable of a decently flat frequency response with a bit more boost afforded to the low end. This is because the tracks that will be mixed on it will tend to be on the bass heavy side, and the ability to listen backwards accurately will be crucial, since tracks will hopefully be published after being mixed on these speakers. (Moulton, p. 313)

Mounting/Rigging needs aren't top priority for now, since this system will likely just sit on top of a desk for the foreseeable future. There will need to be a decision made on what kind of feet the speakers will have and whether they should be propped at an angle.

From the three point design tradeoff system recommended by John Murphey, this speaker system will focus on size, low frequency output, and then SPL needs. (Murphy 1998, p 55)

## 1.2 Post-selection

I heard about the Samba MT kit from my pal Aiden, who also wound up building a pair for themselves. I'm glad I did, because I am very happy with my system, even if the construction was a bit difficult at times for an audio DIY beginner like myself. I decided on this kit because of its ideal enclosure dimensions despite having some pretty powerful drivers included. They aren't as feature-heavy as my reference systems, no Bluetooth here unless I buy an adapter, but for the price that I got them, these are more than I was hoping for and they sound great. I was a bit nervous about putting the passive crossover together, so to make the process easier I ordered a pair of custom printed circuit boards to set all of the components on and used Velcro

to secure them to the bottom of the cabinets to make them easier to access and fix. This turned out to be a good idea, because there was a lot to fix after I got them back up to the U.P. I may need to use glue in the future if there is a problem with the components rattling.



## 2 Reference systems

### 2.1 Overview/Table

To gain context for this design, a comparison was made between several examples of small-size active monitor pairs with a focus on less expensive units. A couple of high budget units were included as well to help gain a broader idea of how these smaller systems can perform.

Speaker	Freq Response	SPL Peak	Weight (lb)	Dimensions (in)	Price (pair,USD)
KRK Rokit G4 5"	43Hz - 40KHz	104	10.69	11H x 7.5W x 9.5D	340
Pioneer DJ DM-50D-BT 5"	54Hz – 30KHz	102	8.6 L 7.7R	10.3H x 6.9W x 10.1D	219
JBL 305P MkII 5"	49Hz – 20KHz	108	10.43	11.7H x 7.3W x 9.1D	258
PreSonus Eris E4.5"	70Hz – 22KHz	100	13	9.4H x 6.4W x 7.1D	150
iLoud Micro 3'	45Hz – 22KHz	104	3.8	7.1H x 3.5W x 5.3D	300
PMC result6 6.5"	45Hz-22KHz	112	17.6	15H x 7.8W x 14.2D	3000

Half of the speakers on this list have a 5-inch woofer, with the other half sporting other sizes for a more varied selection. The Samba kit has 7-inch woofers, which makes it clear that this was a surprising diversion in expectation for the project.

## 2.2 Specific Examples

### *Pioneer DJ DM-50D-BT*



This system from Pioneer DJ has been cited as a great recommendation for beginner producers. One of the key features is the onboard 96 KHz DSP that has two main modes of operation: Production and DJ. Production mode features a flatter frequency response for mixing, while the DJ mode replicates PA speakers for a listening forward experience. Bluetooth connection for smart devices and phones is also included, all around not a bad package for 219 dollars. Some reviews mentioned the sub-bass being pretty weak, and the two locked modes for the DSP makes this a great beginner pick, but likely not something you'll find in a hi-fi studio. I could

not manage to find a visual frequency graph in any of the reviews I read outside of the description of the alternating DSP modes.

<https://www.pioneerdj.com/en-us/product/monitor-speakers/dm-50d-bt/black/overview/>

### *IK Multimedia iLoud Micro-*



Definitely the smallest units on the list, with both speakers weighing just under 4 pounds together, the iLoud Micros are a surprisingly powerful little system. The max SPL is on par with and even higher than some of the other speakers on the list, despite being far more compact, and the frequency response is equally decent. It seems that reviews find these to be pretty impressive, but I think I can afford to have larger woofers with my personal design. (Musicradar 2020)

<https://www.ikmultimedia.com/products/iloudmm/index.php?p=specs>

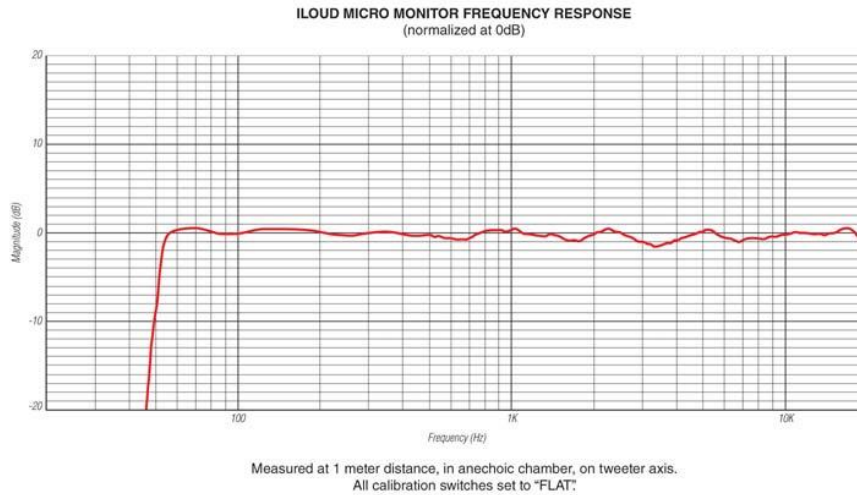

### PreSonus Eris E4.5



These are another example of a good set of entry level studio monitors. As the name suggests, these have 4.5 inch woofers with 1 inch tweeters. The visual design of these speakers is really attractive, the subtle blue tones are great. Pictured here is the Bluetooth 5.0 version of the set, but you can find the non-Bluetooth versions with relative ease. The frequency response is okay for these monitors, with some reviews recommending adding a sub-woofer to make up for what is apparently a weaker low end. (Homedjstudio 2023)

<https://www.presonus.com/en-US/monitors/media-reference-monitors/eris-series/2777500103.html>

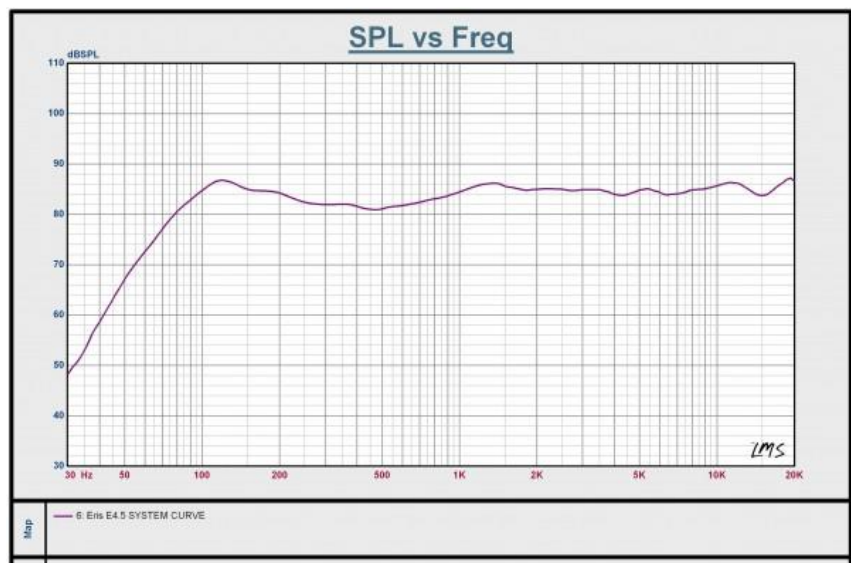

## 3 Technical Specifications

### 3.1 Physical Design/Cabinets

Anticipating the size and listening distance for these speakers is a bit of a complicated task, since the desk that they will be primarily placed on is back downstate, and I did not think to get the dimensions of it before leaving. However, I can still reference the desk that's available to me now, and I've got a pretty strong idea of how I would like them to fit in with the rest of the stuff that I know will also be placed on the desk:

For height, these speakers can be as tall as the computer monitors that they will stand next to. Using my tallest monitor as a reference, these speakers should be around 15-17 inches tall. I can't really foresee this system being mounted anywhere, so the target height shall be 16 inches. The depth should ideally be no more than 9" to ensure that the speakers don't extend too far back and touch the wall behind where they are sitting. Width should be no more than 6", I think 5" is a better target.

The Samba MT kit comes with CNC cut 3/4" MDF enclosure panels. The assembled cabinet dimensions are 15" x 8.5" x 11" (HxWxD). The width and depth are a little bit more than I was hoping for, but I believe that the gain in driver size and quality is a fair tradeoff. The sitting locations on my desk will have to be rearranged a bit more in order to fit these comfortably, but it can be done, and I am definitely willing to accommodate.

As for decoration, I painted the face of the two kits black, and I am intending on wrapping the rest of the pieces in some acoustic felt type material that I acquired from a family member. I'm also considering a splattering of different colors on the front face since the coat of paint I used has since become a bit scuffed, and it could be cool to run with that aesthetic on just that front piece.

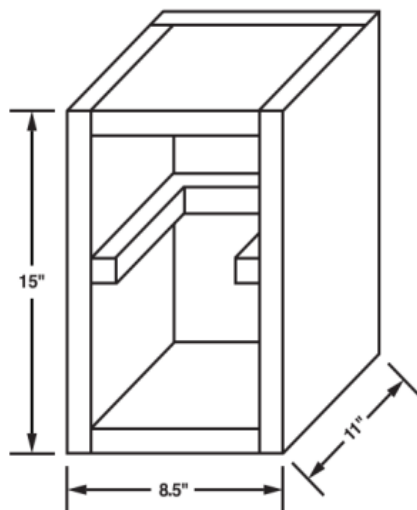



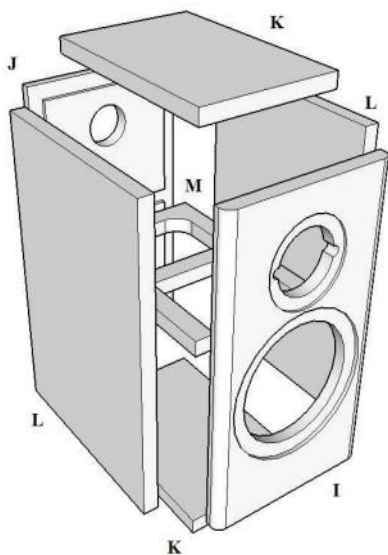

### 3.2 SPL Requirements

To meet K-System standards, particularly the K-20 standard for dynamic range, this system must be able to output a consistent 83dB with 20dB of headroom for wide range content, bringing the peak to 103dB<sup>1</sup>. For music listening, I usually have my system a little louder, around 86dB. Taking a look at some loudness standards for streaming services, Apple music has the largest required headroom at 16dB, so the peak SPL here is 102dB.

Overall, I'd like to achieve a continuous 86dB, with a max of 106dB. 80db minimum with a 100dB minimum peak. This would be at my primary listening location sitting at my desk at just under 1.25 feet (0.381m) away. I was to do an approximate test with my current room and my phone SPL meter, and the Samba kits were more than capable of reaching these levels once I received my new amplifier.

Upon further reflection, I feel that I need to lessen my usual listening level, especially when I am composing or mixing, as listening fatigue and even long term damage is something I have become a bit more sensitive to as I've proceeded through this project.

### 3.3 Drivers

As I've stated a couple of times at this point, I think the drivers that come with this kit are nice for the low price and the size of the kit. The woofer is a Dayton Audio RS180P-4 7" Paper Reference Series, which is a very popular choice for kits and customs because of its nice bass response and low-distortion motor system. This is paired with a Dayton RST28F-4 1-1/8" Reference Series Fabric Dome Tweeter.

### Specs: 7" Reference Series Woofer

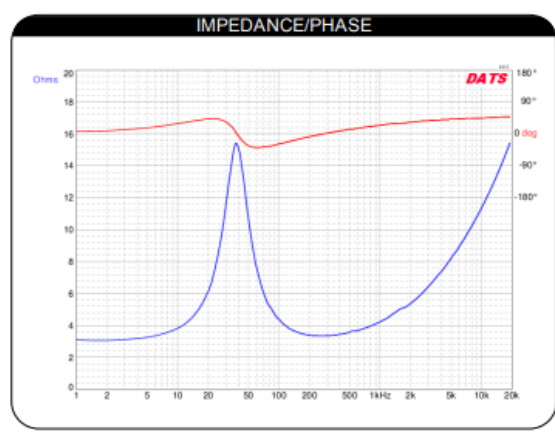
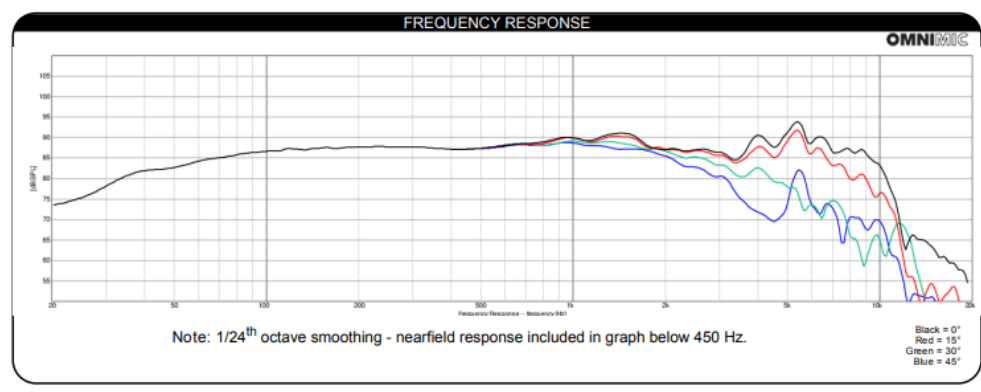

### 1-1/8" Reference Series Tweeter

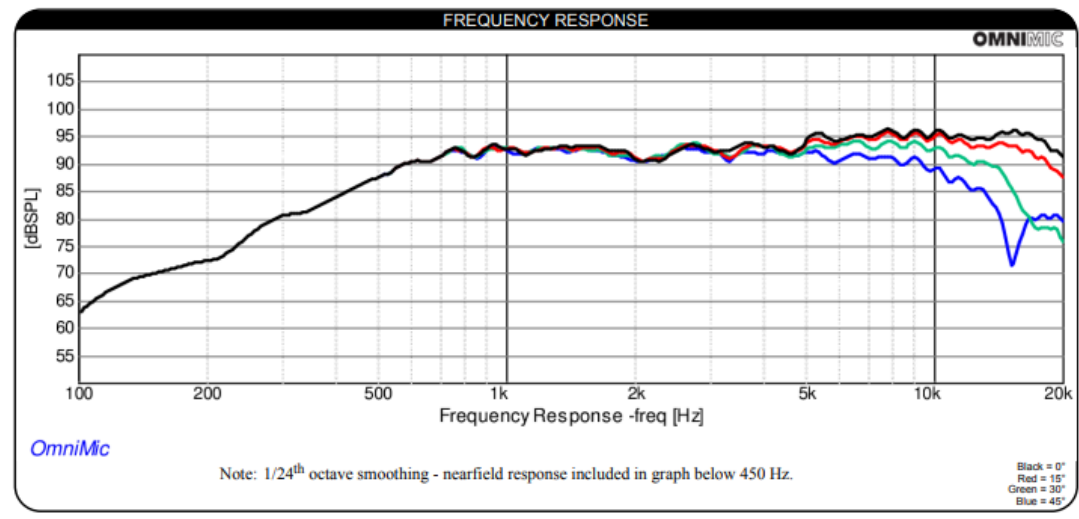

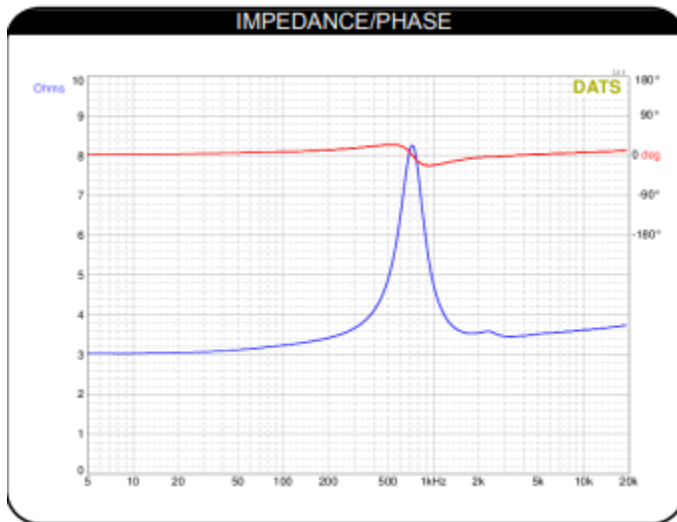

### 3.4 Amplifiers

A 100w amplifier should be sufficient to power this system, choosing a sensitivity of 86dB. 100watts, converted to dBw using  $10\log_{10}(100)$  is 20dBw. This provides the the peak output of 106dB at 1m. This is likely why 100W amplifiers are so commonly used in systems like these. This system will likely be used at levels that are below 100W, but it must be taken into account that passive crossovers can reduce sensitivity a bit.

The amplifier I wound up purchasing was Aiyima AO7 TPA3225 Mini 2 Channel Amplifier, which can provide up to 300W per channel when used with the correct power supply. This is far more than I intend to use, so I opted to use the supply it came with as the configuration maxes out at 150W which is at the max for the kit's components.



### 3.4 Frequency Response

As mentioned, these speakers will be used for mixing quite a bit. Therefore, their frequency response should be as flat as reasonably possible. A boost to the low end is desirable since Hip-Hop tracks tend to require more intense listening in these areas. I would like the low frequency range to extend down to 50Hz, or even lower if possible.

The Samba MT kits provided much of the low-end response that I was looking for. The included port I installed was fully extended, resulting in a tuning frequency of around 41-40 Hz according to the documentation<sup>2</sup>. Something I noticed with Aiden's pair when we tested was that theirs sounded a bit more balanced frequency wise, where mine had a bit more on the bass end, and some of the feedback I received at the listening party reflected that. I believe I am going to do a bit more tuning to see if I can get a fuller sound that will be better for mixing different genres.

## 4 Bibliography

Biernacki, Patryk Patryk. "Presonus Eris E4.5 Review [2023] - Low Cost Studio Monitors." Home DJ Studio, July 24, 2023. <https://homedjstudio.com/presonus-eris-e4-5-review/>.

Corfield, Chris. "IK Multimedia Iloud Micro Monitor Review." MusicRadar, September 29, 2020. <https://www.musicradar.com/reviews/ik-multimedia-iloud-micro-review>.

"DM-50D-BT 5-Inch Desktop Monitor System with Bluetooth® Functionality." Pioneer DJ. Accessed September 12, 2023. <https://www.pioneerdj.com/en-us/product/monitor-speakers/dm-50d-bt/black/overview/>.

"Iloud Micro Monitor by IK Multimedia - Monitoring." KVR Audio. Accessed September 12, 2023. <https://www.kvraudio.com/product/iloud-micro-monitor-by-ik-multimedia>.

"Iloud Micro Monitor." IK MULTIMEDIA. Accessed September 12, 2023. <https://www.ikmultimedia.com/products/iloudmm/index.php?p=specs>.

Monney, Kob. "Pioneer DM-50D." Trusted Reviews, July 19, 2022. <https://www.trustedreviews.com/reviews/pioneer-dm-50d>.

Moulton, David. *Total recording*. Sherman Oaks, CA: KIQ Productions, 2002.

Murphy, John L. *Introduction to loudspeaker design*. Escondido, CA: True Audio, 1998.

"PreSonus® Eris® E4.5 Studio Monitor." Monitors. Accessed September 12, 2023. <https://www.presonus.com/en-US/monitors/media-reference-monitors/eris-series/2777500103.html>.

Other Relevant Links:

The Kit

<https://www.parts-express.com/Samba-MT-Bookshelf-Speaker-Kit-with-Knock-Down-Cabinet-300-7121?quantity=1>

Drivers

<https://www.parts-express.com/Dayton-Audio-RST28F-4-1-1-8-Reference-Series-Fabric-Dome-Tweeter-4-Ohm-275-141?quantity=1>

<https://www.parts-express.com/Dayton-Audio-RS180P-4-7-Reference-Paper-Woofer-4-Ohm-295-375?quantity=1>

Amp

[https://www.amazon.com/dp/B08CJZGT6H?psc=1&ref=ppx\\_yo2ov\\_dt\\_b\\_product\\_details](https://www.amazon.com/dp/B08CJZGT6H?psc=1&ref=ppx_yo2ov_dt_b_product_details)